



CERTIFICATE OF APPROVAL

No CF 328

This is to certify that, in accordance with
TS00 General Requirements for Certification of Fire Protection Products
The undermentioned products of

PILKINGTON UNITED KINGDOM

Hall Lane, Lathom, Lancashire, L40 5UF
Tel: 01744 692000

Have been assessed against the requirements of the Technical Schedule(s)
denoted below and are approved for use subject to the conditions
appended hereto:

CERTIFIED PRODUCT

Pilkington Pyrodur® Plus 30-104
Pilkington Pyrodur® 30-105
Pilkington Pyrodur® 30-201
Pilkington Pyrodur® 30-203
Pilkington Pyrodur®60-10
Pilkington Pyrodur® 60-20
Pilkington Pyrostop® 30-103
Pilkington Pyrostop® 30-10
Pilkington Pyrostop® 30-20
Pilkington Pyrostop® 60-101
Pilkington Pyrostop® 60-201
Pilkington Pyrostop® Line 60-603

TECHNICAL SCHEDULE

TS 25 Fire Resistant Glass,
Glazing Systems and Materials

This certification is provided to the client for their own purposes and we cannot opine on whether it will be accepted by Building Control authorities or any other third parties for any purpose.

Signed and sealed for and on behalf of Warringtonfire Testing and Certification Limited

Paul Duggan
Certification Manager



Issued: 8th July 2004
Re-issued: 23rd October 2019
Valid to: 22nd October 2024





PYRODUR[®] PLUS, PYRODUR[®] AND PYROSTOP[®] FIRE RESISTING GLASS

This Certificate of Approval relates to the fire resistance of Pilkington United Kingdom Limited Laminated glass products when used in the following applications, as defined in BS 476: Part 22: 1987 subject to the undermentioned conditions.

Glass Specification	Application	Fire Resistance Performance (mins)		Page No.
		Integrity	Insulation	
7 mm Pyrodur [®] Plus 30-104	Timber doorsets	30	-	6
7 mm Pyrodur [®] Plus 30-104	Timber screens	30	-	7
7 mm Pyrodur [®] Plus 30-104	Steel doorsets	30	-	9
7 mm Pyrodur [®] Plus 30-104	Steel screens	30	-	10
7 mm Pyrodur [®] Plus 30-104	IGU's timber doorsets	30	-	11
7 mm Pyrodur [®] Plus 30-104	IGU's timber screens	30	-	12
7 mm Pyrodur [®] Plus 30-104	Composite doorsets	30	-	13
7 mm Pyrodur [®] 30-105	Timber doorsets	30	-	14
7 mm Pyrodur [®] 30-105	Timber screens	30	-	15
10 mm Pyrodur [®] 30-201 & 11 mm Pyrodur [®] 30-203	Timber doorsets	30	-	16
10 mm Pyrodur [®] 30-201 & 11 mm Pyrodur [®] 30-203	Timber screens	30	-	17
10 mm Pyrodur [®] 30-201 & 11 mm Pyrodur [®] 30-203	Steel doorsets	30	-	19
10 mm Pyrodur [®] 30-201 & 11 mm Pyrodur [®] 30-203	Steel screens	30	-	20
10 mm Pyrodur [®] 30-201 & 11 mm Pyrodur [®] 30-203	IGU's steel screens	30	-	21
10 mm Pyrodur [®] 30-201 & 11 mm Pyrodur [®] 30-203	IGU's timber screens	30	-	22
10 mm Pyrodur [®] 60-10	Timber Screens	60	-	23
10 mm Pyrodur [®] 60-10	Timber Doorsets	60	-	24
13 mm Pyrodur [®] 60-20	Timber screens	30	-	25
13 mm Pyrodur [®] 60-20	Timber doorsets	60	-	26
13 mm Pyrodur [®] 60-20	Steel doorsets	30	-	27
13 mm Pyrodur [®] 60-20	Steel screens	30	-	28
13 mm Pyrodur [®] 60-20	Steel screens	60	-	29
14 mm Pyrostop [®] 30-103	Timber doorsets	30	30	30
14 mm Pyrostop [®] 30-103	Timber screens	30	30	31
14 mm Pyrostop [®] 30-103	Steel screens	30	30	32
15 mm Pyrostop [®] 30-10, 18 mm Pyrostop [®] 30-20	Timber screens	30	30	33
15 mm Pyrostop [®] 30-10, 18 mm Pyrostop [®] 30-20	Timber doorsets	60	30	35
15 mm Pyrostop [®] 30-10, 18 mm Pyrostop [®] 30-20	Timber screens	60	30	36
15 mm Pyrostop [®] 30-10, 18 mm Pyrostop [®] 30-20	Steel screens	30	30	38
15 mm Pyrostop [®] 30-10, 18 mm Pyrostop [®] 30-20	Steel screens	60	30	39
15 mm Pyrostop [®] 30-10, 18 mm Pyrostop [®] 30-20	IGU's timber screens	30	30	40
15 mm Pyrostop [®] 30-10, 18 mm Pyrostop [®] 30-20	IGU's steel screens	30	30	
15 mm Pyrostop [®] 30-10, 18 mm Pyrostop [®] 30-20	IGU's timber screens	60	30	42
15 mm Pyrostop [®] 30-10, 18 mm Pyrostop [®] 30-20	IGU's steel screens	60	30	
23 mm Pyrostop [®] 60-101	Timber screens	60	60	43
23 mm Pyrostop [®] 60-101	Steel screens	60	60	45
23 mm Pyrostop [®] 60-101	Steel doorsets	60	60	46
23 mm Pyrostop [®] 60-101	IGU's steel screens	60	60	47
23 mm Pyrostop [®] 60-101	IGU's timber screens	60	60	48
23 mm Pyrostop [®] 60-101, 27 mm Pyrostop [®] 60-201	Timber screens	60	60	49
23 mm Pyrostop [®] 60-101, 27 mm Pyrostop [®] 60-201	Steel screens	60	60	50
23 mm Pyrostop [®] 60-101, 27 mm Pyrostop [®] 60-201	Steel doorsets	60	60	51
23 mm Pyrostop [®] 60-101, 27 mm Pyrostop [®] 60-201	IGU's steel screens	60	60	52
23 mm Pyrostop [®] 60-101, 27 mm Pyrostop [®] 60-201	IGU's timber screens	60	60	

Continued.....

Page 2 of 59 Signed
C/003

Issued: 8th July 2004
Reissued: 23rd October 2019
Valid to: 22nd October 2024



PYRODUR® PLUS, PYRODUR® AND PYROSTOP® FIRE RESISTING GLASS

.....continued.

Glass Specification	Application	Fire Resistance Performance (mins)		Page No.
		Integrity	Insulation	
23 & 27 mm Pyrostop® Line 60-603	Butt jointed timber screens	60	60	53
		30	30	
23 & 27 mm Pyrostop® Line 60-603	Butt jointed steel screens	60	60	54
		30	30	
15-27 mm Pyrostop®	IGU's steel screens	90	90	55
23 mm Pyrostop® 60-101	IGU's steel screens	120	120	56
23 mm Pyrostop® 60-101, 27 mm Pyrostop® 60-201	IGU's steel screens	120	120	57
10 mm Pyrodur® 30-201 & 30-203	SAPA Alu. screens	30	-	58
15 mm Pyrostop® 30-10, 18 mm Pyrostop® 30-20	SAPA Alu. screens	60	30	
15 mm Pyrostop® 30-10, 18 mm Pyrostop® 30-20	SAPA Alu. doorsets	60	30	59

Page 3 of 59 Signed
C/003

Issued: 8th July 2004
Reissued: 23rd October 2019
Valid to: 22nd October 2024



PYRODUR® PLUS, PYRODUR® AND PYROSTOP® FIRE RESISTING GLASS

This product is approved on the basis of:

- i) Initial type testing
- ii) A design appraisal against TS25
- iii) Registration to ISO9001: 2008
- iv) Inspection and surveillance of factory production control.

This Certificate of Approval must be read in conjunction with CERTIFIRE Technical Schedule TS25, Fire Resistant Glass, Glazing Systems and Materials.

General Requirements

- Where the glass is installed in a timber or steel framed screen, the orientation of the screen shall be no more than $\pm 10^\circ$ from the vertical.
- There is no restriction to the direction of exposure for the glass, unless specifically stated. Orientation may, however, be restricted by the requirements of a non-symmetrical framing system or by the manufacturer's recommendations.
- Some restrictions apply to the use of Insulating Glass Units (IGU's) with regards to the orientation of the non-fire rated glass component.
- The edge cover to each pane shall be no less than 15 mm minimum.
- Decorative or manifestation films and surface finishing (i.e. sandblasted or acid etched finishes) may be applied to the glasses included within the scope of this certificate.
- IGU's may include either aluminium, warm edge or steel spacer bars, 6-27 mm wide where appropriate.
- IGU's must be fabricated by a processor audited and certificated under appropriate CPR legislation.
- IGU's may incorporate blinds or fretwork within the cavity. There is no restriction on the orientation of the unit. The fitment of such blinds should not necessitate the removal of any framing or beading material and should be operated via a remote system (i.e. operating system may be magnetic). Pilkington United Kingdom Limited should be consulted prior to specifying integral blinds to ensure acceptability.
- IGU's, where included within the scope of this Certificate, may comprise double or triple glazed units. Note: 7 mm Pyrodur® Plus 30-104 may only be glazed in double glazed unit configurations.



PYRODUR[®] PLUS, PYRODUR[®] AND PYROSTOP[®] FIRE RESISTING GLASS

Specific Considerations for Doorset Applications

Where scope is provided for glass to be used within timber doorsets, the following should be considered and any requirements complied with:

- The doorset, including door frame and associated building hardware, should have achieved at least the required performance when tested, or subsequently assessed by one of the laboratories approved by CERTIFIRE as acceptable for this purpose, to BS 476: Part 22: 1987 or BS EN 1634-1: 2000.
- The proposed doorset should also have included a glazed aperture or apertures of the intended size, shape, area and number.
- When used to glaze CERTIFIRE approved doorsets which have smaller apertures than allowed in this certificate, the aperture sizes specified in the doorset certificate shall take precedence.
- The door leaves shall consist of timber faces coupled with timber or other cellulosic cores of the specified minimum overall leaf thickness, 44 mm for 30 minute doors and 54 mm for 60 minute doors
- When an alternative CERTIFIRE approved glazing system is used, the system shall have been shown to be capable of including the relevant glass. The maximum permitted aperture dimensions shall be as detailed below or included within the relevant CERTIFIRE certificate for the glazing system, whichever is the lesser.
- Other CERTIFIRE approved glazing seals may be acceptable subject to the limitations within the relevant certificate.

Glazing Tapes

The following glazing tapes may be utilised with Pilkington Pyrodur[®] and Pilkington Pyrostop[®] products in this certificate, up to a maximum fire resistance performance of 60 minutes:

- Tremco Illbruck TN131 / TN136
- Technibond HTA / Techniseal TS110/220/330
- Mann Mcgowan – closed cell foam tape
- Exitex – closed cell foam tape
- Fire & Acoustic closed cell foam tape
- UK Industrial tapes – FoamLink 1103H+ / 1603H+/3003H+
- Vetec UK – Flexitec Glazing tape

PYRODUR® PLUS FIRE RESISTING GLASS

7 mm Pyrodur® Plus Glass in timber based doorsets for periods of 30 minutes integrity

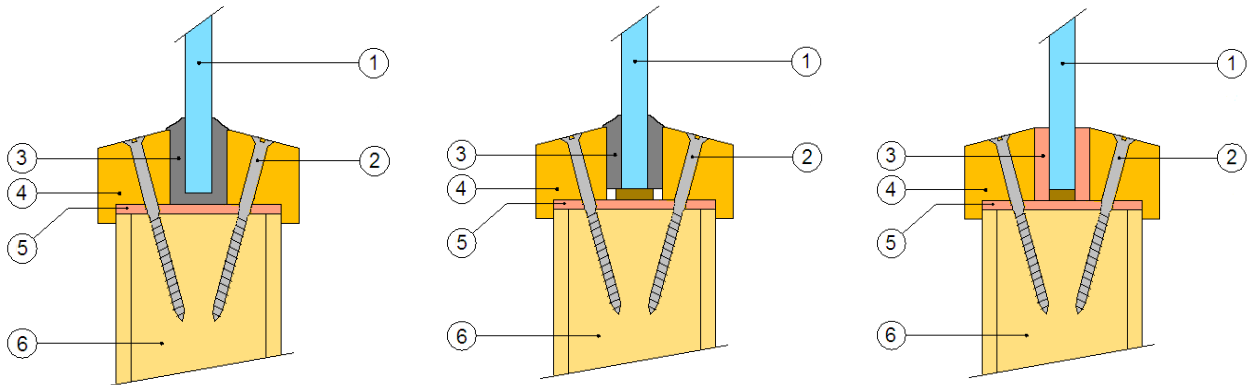

1. Pyrodur® Plus 30-104 (7 mm thick)
2. 40 mm pins or screws, 200 mm centres, fixed at 30°
3. System 36/7 glazing channel
4. Hardwood beads, 550 kg/m³ min. density, min. 17 mm high by 22 mm wide (including 4 mm high by 4 mm wide bolection), square or 15° chamfer
5. 2 mm thick Palusol liner
6. Nominally 44 mm thick FD30 door leaf

1. Pyrodur® Plus 30-104 (7 mm thick)
2. 40 mm pins or screws, 150 mm centres, fixed at 30°
3. Flexible Figure 1 glazing system
4. Hardwood beads, 550 kg/m³ min. density, min. 20 mm high by 22 mm wide (including 5 mm high by 5 mm wide bolection), square or 15° chamfer
5. 2 mm thick Palusol liner
6. Nominally 44 mm thick FD30 door leaf

1. Pyrodur® Plus 30-104 (7 mm thick)
2. 38 mm pins or screws, 150 mm centres, fixed at 30°
3. Interdens, 20 mm by 2 mm
4. Hardwood beads, 660 kg/m³ min. density, min. 24 mm high by 20 mm wide (including 4 mm high by 4 mm wide bolection), square or 15° chamfer
5. 2 mm thick Palusol liner
6. Nominally 44 mm thick FD30 door leaf

The doorset shall have test evidence or be CERTIFIRE approved for the inclusion of apertures of the proposed dimensions.

This Certificate of Approval relates to the sizes of Pyrodur® Plus glass shown in the table below, when used in conjunction with the above system:

	System 36/7	Flexible Figure 1	20 mm by 2 mm Interdens
Maximum Aperture Height	875 mm (at 750 mm wide)	875 mm (at 750 mm wide)	2050 mm (at 1093 mm wide)
Maximum Aperture Width	750 mm (at 875 mm high)	750 mm (at 875 mm high)	950 mm (at 2358 mm high)
Maximum Aperture Area	0.66 m ²	0.66 m ²	2.24 m ²
The aspect ratio of the glass may be unlimited within these aperture dimensions			

PYRODUR® PLUS FIRE RESISTING GLASS

7 mm Pyrodur® Plus 30-104 in timber framed screens for periods of 30 minutes integrity

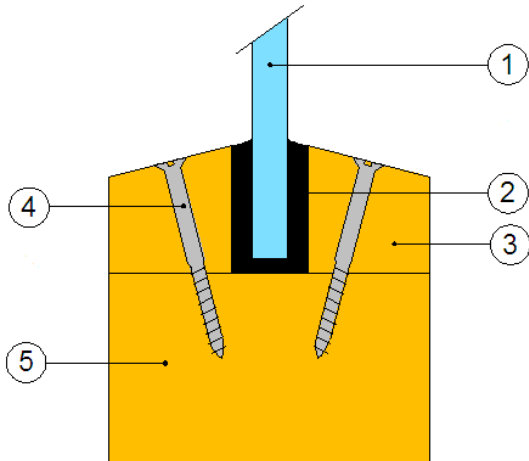

1. Pyrodur® Plus 30-104 (7 mm thick)
2. Lorient System 36/7 glazing channel
3. Softwood or hardwood beads, 550 kg/m³ minimum density, 15 mm high by 22 mm wide minimum dimensions, square or up to 15° chamfer.
4. 40 mm pins or screws, 200 mm centres, fixed at 45°
5. Softwood or hardwood frame, 550 kg/m³ minimum density, 94 mm by 44 mm minimum section size.

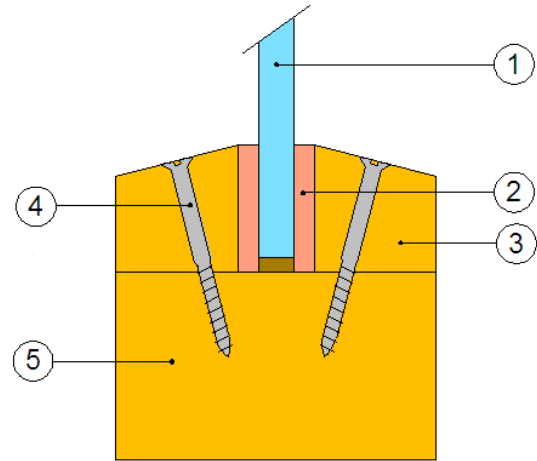

1. Pyrodur® Plus 30-104 (7 mm thick)
2. Interdens, 20 mm by 2 mm
3. Hardwood beads, 640 kg/m³ minimum density, 20 mm high by 20 mm wide minimum dimensions, square or up to 15° chamfer.
4. 38 mm pins or 60 mm long screws, 150 mm centres, fixed at 30°
5. Hardwood frame, 640 kg/m³ minimum density, 90 mm by 45 mm minimum section size.

This Certificate of Approval relates to the sizes of Pyrodur® Plus 30-104 glass shown in the table below, when used in conjunction with the above systems:

	System 36/7	20 mm by 2 mm Interdens (Screw fixings)	20 mm by 2 mm Interdens (Pin fixings)
Maximum Aperture Height	2320 mm (at 1078 mm wide)	2050 mm (at 1790 mm wide)	2050 mm (at 1454 mm wide)
Maximum Aperture Width	1082 mm (at 2311 mm high)	2050 mm (at 1790 mm high)	1726 mm (at 1726 mm high)
Maximum Aperture Area	2.50 m ²	3.67 m ²	2.98 m ²
The aspect ratio of the glass may be unlimited within these aperture dimensions			

PYRODUR® PLUS FIRE RESISTING GLASS

7 mm Pyrodur® Plus 30-104 in timber framed screens for periods of 30 minutes integrity

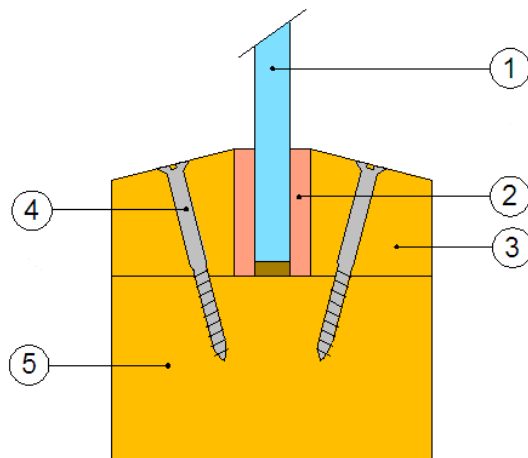

1. Pyrodur® Plus 30-104 (7 mm thick)
2. Ceramic fibre tape, 20 mm x 3 mm (uncompressed)*
3. Softwood or hardwood beads, 415 kg/m³ minimum density, 20 mm high by 20 mm wide minimum dimensions, square or up to 20° chamfer.
4. 40 mm pins (Ø1.6mm) or 40 mm long screws, 150 mm centres, fixed at 20°
5. Softwood or hardwood frame, 415kg/m³ minimum density, 70 mm by 33 mm minimum section size.

*Ceramic fibre glazing tape may be replaced with any CERTIFIRE approved glazing gasket system.

This Certificate of Approval relates to the sizes of Pyrodur® Plus 30-104 glass shown in the table below, when used in conjunction with the above system:

Maximum Height	Maximum Width	Maximum Area
2439 mm high (at 902 mm wide)	1128 mm wide (at 1951 mm high)	2.2 m ²
The aspect ratio of the glass may be unlimited within these aperture dimensions		

PYRODUR® PLUS FIRE RESISTING GLASS

7 mm Pyrodur® Plus 30-104 in steel based doorsets for periods of 30 minutes integrity

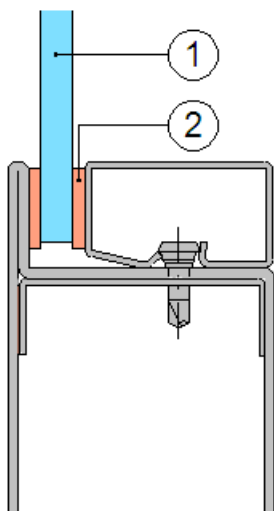

1. Pyrodur® Plus 30-104 (7mm thick)
2. Fibrefrax tape, 15 mm by 2 mm

The doorset shall have test evidence or be CERTIFIRE approved for the inclusion of apertures of the proposed dimensions. The specification of the glazing beads and their method of attachment shall also be as tested or CERTIFIRE approved.

This Certificate of Approval relates to the sizes of Pyrodur® Plus 30-104 glass shown in the table below, when used in conjunction with the above system:

Maximum Aperture Height	Maximum Aperture Width	Maximum Aperture Area
2050 mm	1069 mm	2.19 m ²
The aspect ratio of the glass may be unlimited within these aperture dimensions		

PYRODUR® PLUS FIRE RESISTING GLASS

7 mm Pyrodur® Plus 30-104 in steel framed screens for periods of 30 minutes integrity

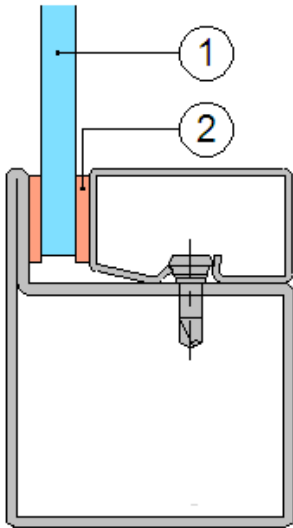

1. Pyrodur® Plus 30-104 (7mm thick)
2. Fibrefrax tape, 15 mm by 2 mm

The framing system shall have test evidence or be CERTIFIRE approved for the inclusion of apertures of the proposed dimensions.

This Certificate of Approval relates to the sizes of Pyrodur® Plus 30-104 glass shown in the table below, when used in conjunction with the above system:

Maximum Aperture Height	Maximum Aperture Width	Maximum Aperture Area
2050 mm (at 1139 mm wide)	1690 mm (at 1690 mm high)	2.86 m ²
The aspect ratio of the glass may be unlimited within these aperture dimensions		

PYRODUR® PLUS FIRE RESISTING GLASS

Insulating Glass Units (IGUs)* including 7 mm Pyrodur® Plus 30-104 Glass in timber based doorsets for periods of 30 minutes integrity

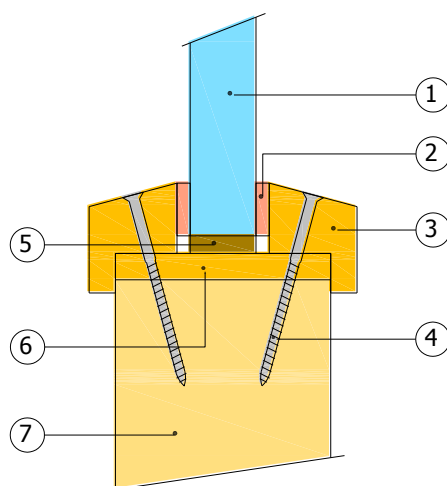

1. IGU comprising 7 mm thick Pyrodur® 30-104, a 6 mm wide air cavity and 6.4 mm thick non-fire rated glass (Optilam S3)
2. Ceramic fibre tape, 20 mm x 3 mm (compressed to 2 mm)
3. Hardwood beads, 640 kg/m³ minimum density, 20 mm high by 15 mm wide inc. 5 mm by 5 mm bolection minimum dimensions, square or up to 20° chamfer.
4. 50 mm screws, 150 mm centres, fixed at 45°,
5. Interdens liner, 10 mm by 2mm
6. Hardwood liner
7. FD30 door leaf

This Certificate of Approval relates to the sizes of insulating glass units incorporating Pyrodur® Plus 30-104 glass shown in the table below, when used in conjunction with the above system:

Maximum Height	Maximum Width	Maximum Area
1875 mm high (at 600 mm wide)	750 mm wide (at 1500 mm high)	1.13 m ²

***Note: Pyrodur® Plus 30-104 may only be included in double glazed options. Triple glazed units are not approved for this glass**

PYRODUR® PLUS FIRE RESISTING GLASS

Insulating Glass Units (IGUs)* including 7 mm Pyrodur® Plus 30-104 in timber framed screens for periods of 30 minutes integrity

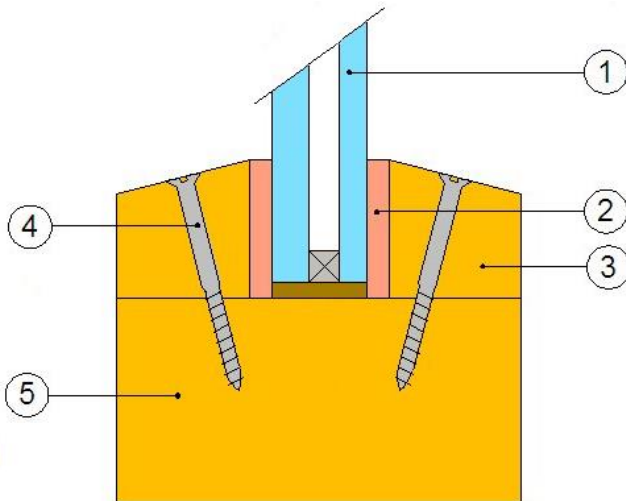

1. IGU comprising 7 mm thick Pyrodur® 30-104, a 6 mm wide air cavity and 6.4 mm thick non-fire rated glass (Optilam S3).
2. Fibrefrax ceramic glazing tape, 20 mm by 3 mm (compressed to 2 mm).
3. Hardwood beads, 640 kg/m³ min. density, min. 20 mm high by 25 mm wide, square or up to 15° chamfer.
4. 50 mm screws, 150 mm centres, fixed at 45°.
5. Softwood, 510 kg/m³ min. density, min. 80 mm by 44 mm

Note: A 10 mm by 2 mm Interdens liner must be used to line the glazing aperture

This Certificate of Approval relates to the sizes of insulating glass units incorporating Pyrodur® Plus 30-104 glass shown in the table below, when used in conjunction with the above system:

Maximum Height	Maximum Width	Maximum Area
1820 mm high (at 700 mm wide)	750 mm wide (at 1700 mm high)	1.27 m ²

***Note:** Pyrodur® Plus 30-104 may only be included in double glazed options. Triple glazed units are not approved for this glass



PYRODUR[®] PLUS FIRE RESISTING GLASS

Insulating Glass Units (IGUs)* including 7 mm Pyrodur[®] Plus 30-104 or 30-105 Glass in composite doorsets for periods of 30 minutes integrity

Approval of insulating glass units incorporating 7 mm Pyrodur[®] Plus glass is approved, at the dimensions given below, for use in certain specific designs of composite doorset (including side screens). Pilkington United Kingdom Limited should be contacted for further information on suitable applications.

	Maximum Height	Maximum Width	Maximum Area
Within Door Leaf	1040 mm high (at 558 mm wide)	636 mm wide (at 912 mm high)	0.58 m ²
Within Side screen	1862 mm high (at 900 mm wide)	1125 mm wide (at 1490 mm high)	1.68 m ²

***Note: Pyrodur[®] Plus 30-104 or 30-105 may only be included in double glazed options. Triple glazed units are not approved for this glass**

PYRODUR® PLUS FIRE RESISTING GLASS

7 mm Pyrodur® 30-105 Glass in timber based doorsets for periods of 30 minutes integrity

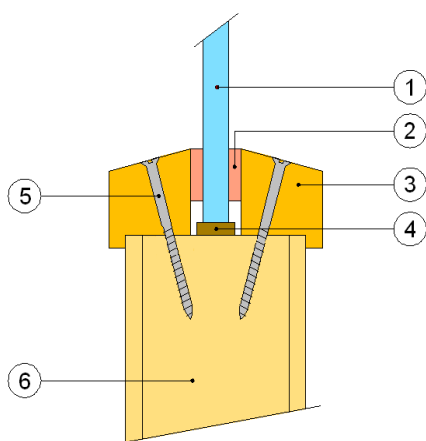

1. Pyrodur® 30-105
2. Ceramic fibre Tape 15 x 3 mm. Ceramic fibre glazing tape may be replaced with any CERTIFIRE approved glazing gasket system.
3. MDF or Softwood or Hardwood glazing beads (min. 510 kg/m³ density), minimum 20.5mm wide by 20mm high, including 5 mm x 5 mm bolection return, chamfered by approximately 15°
4. Setting blocks
5. Minimum 40mm long steel pins (1.6mm diameter) or screws fitted at nominally 50 mm in from the corners, at a maximum of 150mm centres, angled at 45° to the face of the glass
6. Single European Redwood Stile and Rail door and frame of size 70 mm deep by 44 mm thick and density of at least 510 kg/m³ or FD30 timber based door leaves (liner may be required as detailed in door test certificate)

The doorset shall have test evidence or be CERTIFIRE approved for the inclusion of apertures of the proposed dimensions.

This Certificate of Approval relates to the sizes of Pyrodur® 30-105 glass shown in the table below, when used in conjunction with the above system:

Maximum Aperture Height	2280 mm (at 694 mm wide)
Maximum Aperture Width	867 mm (at 1824 mm high)
Maximum Aperture Area	1.58 m ²
The aspect ratio of the glass may be unlimited within these aperture dimensions	

PYRODUR® PLUS FIRE RESISTING GLASS

7 mm Pyrodur® 30-105 in timber framed screens for periods of 30 minutes integrity

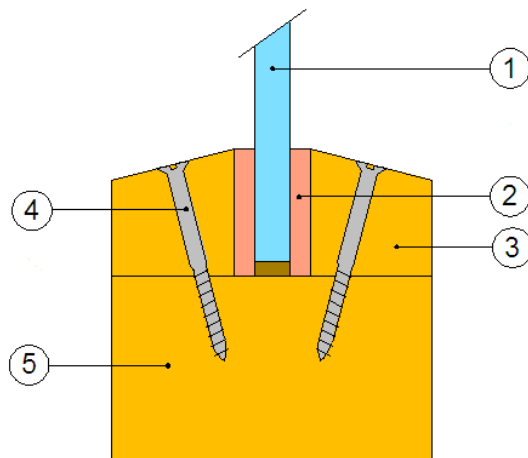

1. Pyrodur® 30-105 2.
2. Ceramic fibre tape, 15 mm x 3 mm. Ceramic fibre glazing tape may be replaced with any CERTIFIRE approved glazing gasket system.
3. Softwood or Hardwood beads, 510 kg/m³ minimum density, 20 mm high by 18 mm wide minimum dimensions, square or chamfered.
4. 40 mm pins (Ø1.6mm) or 40 mm long screws, 50 mm in from corners at 150 mm centres, fixed at 20°
5. Softwood or hardwood frame, 510kg/m³ minimum density, 70 mm by 32 mm minimum section size.

This Certificate of Approval relates to the sizes of Pyrodur® Plus 30-105 glass shown in the table below, when used in conjunction with the above system:

Maximum Height	Maximum Width	Maximum Area
3000 mm high (at 1000 mm wide)	1250 mm wide (at 3000 mm high)	3.66 m ²
978 mm high (at 1892 mm wide)	2365 mm wide (at 738 mm high)	1.85 m ²
The aspect ratio of the glass may be unlimited within these aperture dimensions		

PYRODUR® FIRE RESISTING GLASS

10 mm Pyrodur® 30-201 & 30-203 in timber based doorsets for periods of 30 minutes integrity

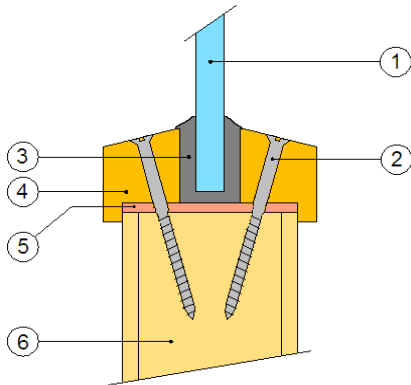

1. Pyrodur® 30-201 & 30-203 (10 mm thick)
2. 45 mm screws, 200 mm centres, fixed at 30°
3. System 36/10 glazing channel
4. Hardwood beads, 550 kg/m³ min. density, min. 20 mm high by 18.5 mm wide (including 5 mm high by 5 mm wide bolection), square or 15° chamfer
5. 2 mm thick Palusol liner
6. Nominally 44 mm thick FD30 door leaf

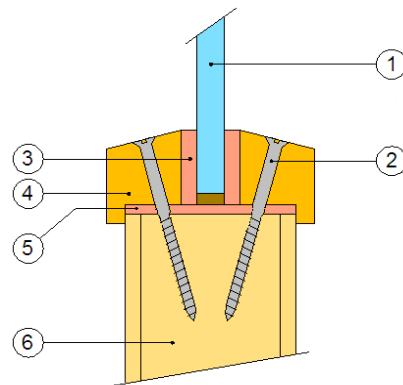

1. Pyrodur® 30-201 & 30-203 (10 mm thick)
2. 38 mm screws, 200 mm centres, fixed at 45°
3. Interdens, 10 mm by 2 mm
4. Hardwood beads, 640 kg/m³ min. density, min. 24 mm high by 19 mm wide (including 4 mm high by 4 mm wide bolection), square or 15° chamfer
5. 12 mm thick hardwood liner
6. Nominally 44 mm thick FD30 door leaf

This Certificate of Approval relates to the sizes of 10 mm Pyrodur® 30-201 & 30-203 shown in the table below, when used in conjunction with the above system:

	System 36/10	10 mm by 2 mm Interdens
Maximum Aperture Height	1800 mm (at 600 mm wide)	2240 mm (at 965 mm wide)
Maximum Aperture Width	600 mm (at 1800 mm high)	965 mm (at 2240 mm high)
Maximum Aperture Area	1.08 m ²	2.16 m ²
The aspect ratio of the glass may be unlimited within these aperture dimensions		

The doorset shall have test evidence or be CERTIFIRE approved for the inclusion of apertures of the proposed dimensions.

PYRODUR® FIRE RESISTING GLASS

10 mm Pyrodur® 30-201 & 30-203 in timber framed screens for periods of 30 minutes integrity

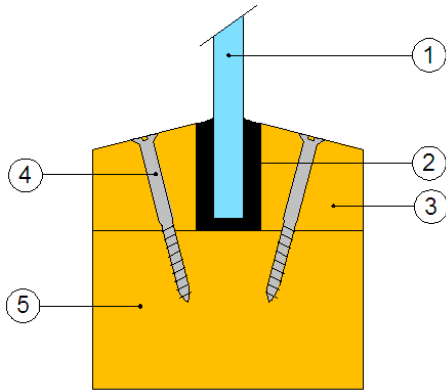

1. Pyrodur® 30-201 & 30-203 (10 mm thick)
2. Lorient System 36/10 glazing channel
3. Softwood or hardwood beads, 530 kg/m³ minimum density, 21 mm high by 15 mm wide minimum dimensions, square or up to 15° chamfer.
4. 45 mm screws, 200 mm centres, fixed at 45°
5. Softwood or hardwood frame, 530 kg/m³ minimum density, 90 mm by 45 mm minimum section size.

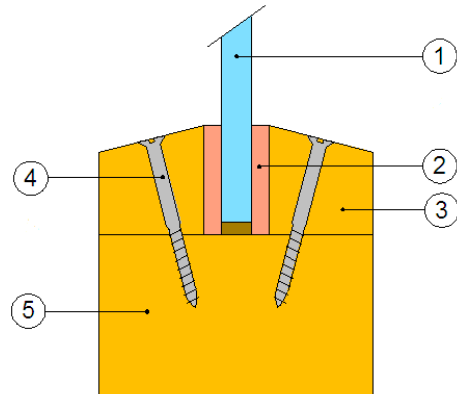

1. Pyrodur® 30-201 & 30-203 (10 mm thick)
2. Interdens, 20 mm by 2 mm
3. Hardwood beads, 660 kg/m³ minimum density, 20 mm high by 25 mm wide minimum dimensions, square or up to 15° chamfer.
4. 38 mm long pins or screws, 200 mm centres, fixed at 45°
5. Hardwood frame, 660 kg/m³ minimum density, 80 mm by 30 mm minimum section size.

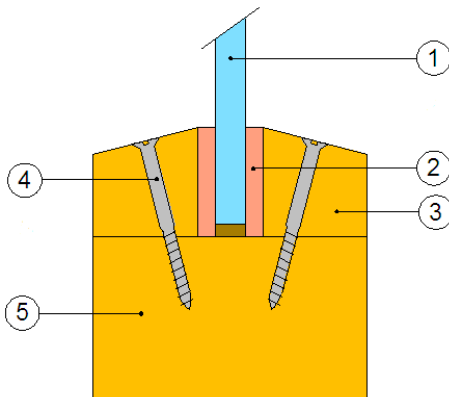

1. Pyrodur® 30-201 & 30-203 (10 mm thick)
2. Fireglaze Compound, 15 mm by 2 mm
3. Hardwood beads, 600 kg/m³ minimum density, 15 mm high by 25 mm wide minimum dimensions, square or up to 15° chamfer.
4. 38 mm pins or screws, 200 mm centres, fixed at 45°
5. Hardwood frame, 600 kg/m³ minimum density, 80 mm by 25 mm minimum section size.

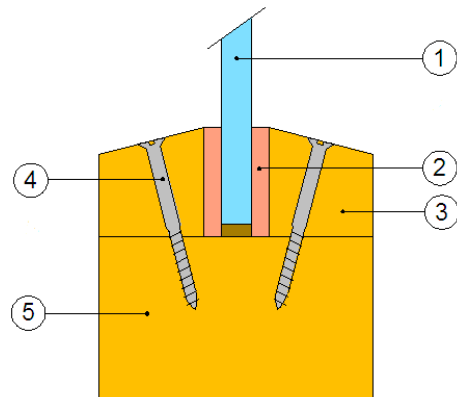

1. Pyrodur® 30-201 & 30-203 (10 mm thick)
2. Fireglaze G30, 15 mm by 2 mm
3. Hardwood beads, 510 kg/m³ minimum density, 15 mm high by 25 mm wide minimum dimensions, square or up to 25° chamfer.
4. 50 mm pins or screws, 150 mm centres, fixed at 35°
5. Softwood or hardwood frame, 510 kg/m³ minimum density, 95 mm by 45 mm minimum section size.

PYRODUR® FIRE RESISTING GLASS

10 mm Pyrodur® 30-201 & 30-203 in timber framed screens for periods of 30 minutes integrity (cont.)

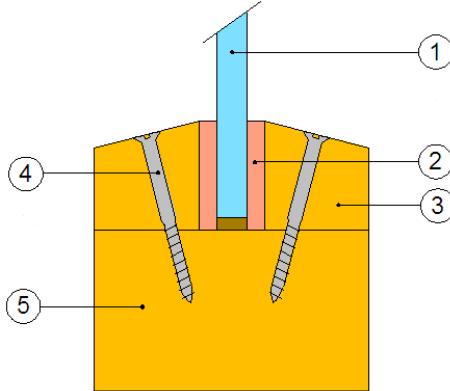

1. Pyrodur® 30-201 & 30-203 (10 mm thick)
2. Ceramic fibre tape, 15 mm by 4 mm*
3. Softwood or hardwood beads, 450 kg/m³ minimum density, 20 mm high by 30 mm wide minimum dimensions, square or up to 15° chamfer.
4. Screws, 4 mm x 50 mm, 200 mm centres, fixed at 45°
5. Softwood frame, 450 kg/m³ minimum density, 75 mm by 33 mm minimum section size.

*Ceramic fibre glazing tape may be replaced with any CERTIFIRE approved glazing gasket system.

This Certificate of Approval relates to the sizes of 10 mm Pyrodur® 30-201 & 30-203 shown in the table below, when used in conjunction with the previously detailed systems:

Maximum Height	Maximum Width	Maximum Area
2875mm high (at 1200 mm wide)	1500 mm wide (at 2300 mm high)	3.45 m ²
1250 mm high (at 1646 mm wide)	2057 mm wide (at 1000 mm high)	2.06 m ²
The aspect ratio of the glass may be unlimited within these aperture dimensions		

PYRODUR® FIRE RESISTING GLASS

10 mm Pyrodur® 30-201 & 30-203 in steel based doorsets for periods of 30 minutes integrity

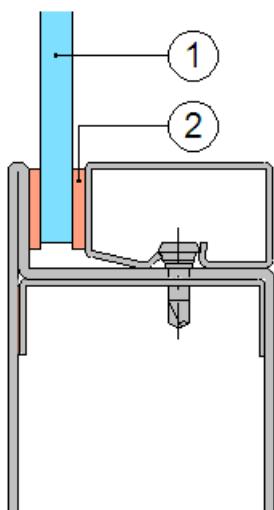

1. Pyrodur® 30-201 & 30-203 (10 mm thick)
2. Fibrefrax tape, 15 mm by 2 mm

The doorset shall have test evidence or be CERTIFIRE approved for the inclusion of apertures of the proposed dimensions. The specification of the glazing beads and their method of attachment shall also be as tested or CERTIFIRE approved.

This Certificate of Approval relates to the sizes of 10 mm Pyrodur® 30-201 & 30-203 shown in the table below, when used in conjunction with the above system:

Maximum Aperture Height	Maximum Aperture Width	Maximum Aperture Area
2415 mm	1069 mm	2.58 m ²
The aspect ratio of the glass may be unlimited within these aperture dimensions		

PYRODUR® FIRE RESISTING GLASS

10 mm Pyrodur® 30-201 & 30-203 in steel framed screens for periods of 30 minutes integrity

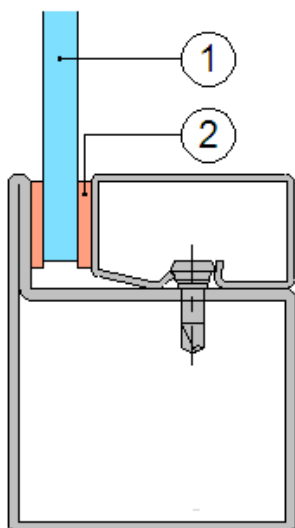

1. Pyrodur® 30-201 & 30-203 (10 mm thick)
2. Fibrefrax tape, 15 mm by 2 mm

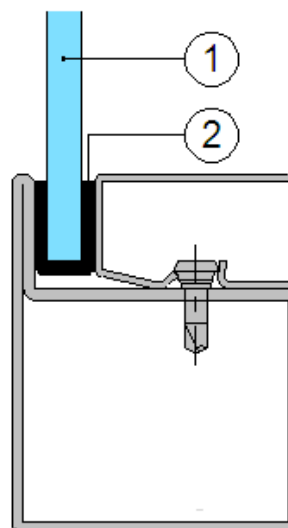

1. Pyrodur® 30-201 & 30-203 (10 mm thick)
2. Lorient System 36/10 glazing gasket

The framing system shall have test evidence or be CERTIFIRE approved for the inclusion of apertures of the proposed dimensions.

This Certificate of Approval relates to the sizes of 10 mm Pyrodur® 30-201 & 30-203 shown in the table below, when used in conjunction with the above systems:

Glazing Seal Reference	Maximum Aperture Height	Maximum Aperture Width	Maximum Aperture Area
15 mm by 2 mm Fibrefrax	3000 mm (at 1801 mm wide)	2561 mm (at 2000 mm high)	5.40 m ²
System 36/10	2000 mm (at 1400 mm wide)	1400 mm (at 2000 mm high)	2.80 m ²
The aspect ratio of the glass may be unlimited within these aperture dimensions			

PYRODUR® FIRE RESISTING GLASS

Insulating Glass Units (IGUs) including 10 mm Pyrodur® 30-201 & 30-203 in steel framed screens for periods of 30 minutes integrity

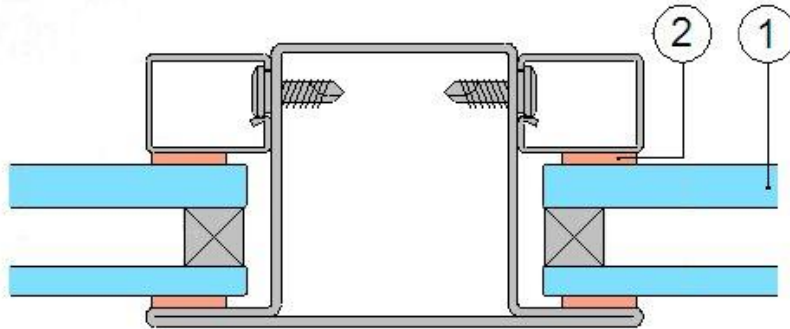

1. 24 mm thick IGU comprising 10 mm thick Pyrodur® 30-201 & 30-203, an 8 mm wide air cavity and 6 mm thick non-fire rated glass (toughened, float, laminated glass)
2. 15 mm by 2 mm Fibrefrax glazing tape

The framing system shall have test evidence or be CERTIFIRE approved for the inclusion of apertures of the proposed dimensions.

This Certificate of Approval relates to the sizes of the IGUs shown in the table below, when used in conjunction with the above system:

Maximum Aperture Height	Maximum Aperture Width	Maximum Aperture Area
3000 mm (at 1786 mm wide)	2417 mm (at 2000 mm high)	5.36 m ²
The aspect ratio of the glass may be unlimited within these aperture dimensions		

PYRODUR® FIRE RESISTING GLASS

Insulating Glass Units (IGUs) including 10 mm Pyrodur® 30-201 & 30-203 in timber framed screens for periods of 30 minutes integrity

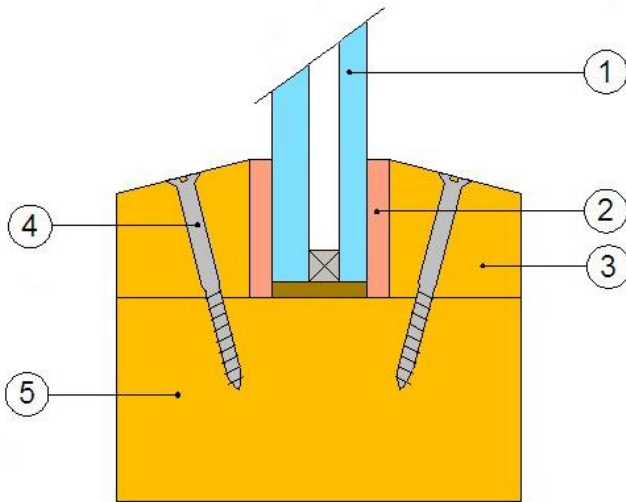

1. 24 mm thick IGU comprising 10 mm thick Pyrodur® 30-201 & 30-203, an 8 mm wide air cavity and 6 mm thick non-fire rated glass (toughened, float, laminated glass).
2. Interdens, 20 mm by 2 mm.
3. Hardwood beads, 660 kg/m³ min. density, min. 20 mm high by 25 mm wide, square or up to 15° chamfer.
4. 38 mm pins or screws, 200 mm centres, fixed at 45°.
5. Hardwood, 660 kg/m³ min. density, min. 80 mm by 30 mm

This Certificate of Approval relates to the sizes of the IGUs shown in the table below, when used in conjunction with the above system:

	20 mm by 2 mm Interdens
Maximum Aperture Height	2456 mm (at 1213 mm wide)
Maximum Aperture Width	2500 mm (at 1192 mm high)
Maximum Aperture Area	2.98 m ²

PYRODUR® FIRE RESISTING GLASS

10 mm Pyrodur® 60-10 in timber framed screens for periods of 60 minutes integrity

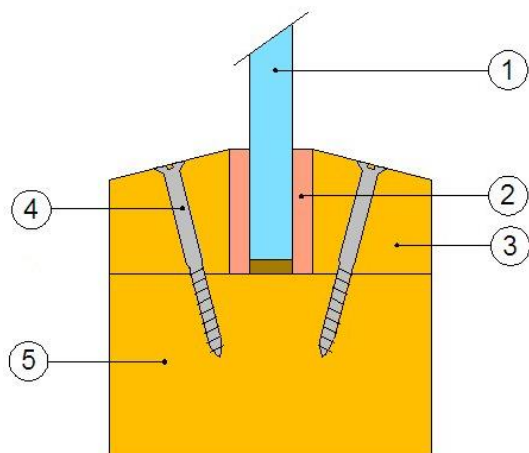

1. 10 mm thick Pyrodur® 60-10 glass.
2. Hodgsons Firestrip 60, 20 mm by 3 mm.
3. Hardwood beads, 640 kg/m³ min. density, min. 20 mm high by 40 mm wide, square or up to 15° chamfer.
4. 60 mm screws, 150 mm centres, fixed at 45°.
5. Hardwood, 640 kg/m³ min. density, min. 95 mm by 45 mm

This Certificate of Approval relates to the sizes of 10 mm Pyrodur® 60-10 shown in the table below, when used in conjunction with the above system:

Maximum Height	Maximum Width	Maximum Area
2103 mm high (at 850 mm wide)	910 mm wide (at 1965 mm high)	1.79 m ²
The aspect ratio of the glass may be unlimited within these aperture dimensions		

PYRODUR® PLUS FIRE RESISTING GLASS

10 mm Pyrodur® 60-10 in timber based doorsets for periods of 60 minutes integrity

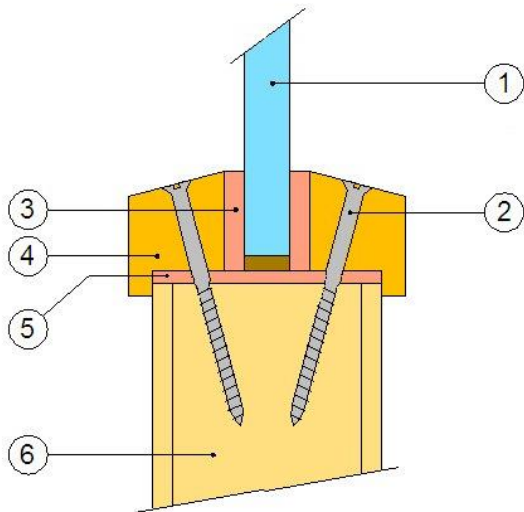

1. 10 mm thick Pyrodur® 60-10 glass.
2. 60 mm long (minimum) screw fixings at 150 mm centres angled at 30° to glass.
3. Hodgsons Firestrip 60, 20 mm by 3 mm
4. 20 mm high by 24 mm wide with a 5 mm by 5 mm bolection, square or chamfered (maximum of 15°) hardwood glazing beads of minimum 640 kg/m³ density
5. 50 mm wide by 2 mm thick Norseal flexible aperture liner
6. Nominally 54 mm thick FD60 door leaf, with a hardwood aperture liner

The doorset shall have test evidence or be CERTIFIRE approved for the inclusion of apertures of the proposed dimensions.

This Certificate of Approval relates to the sizes of Pyrodur® 60-10 shown in the table below, when used in conjunction with the above system:

Maximum Aperture Height	Maximum Aperture Width	Maximum Aperture Area
1915 mm high (at 792 mm wide)	847 mm wide (at 1790 mm high)	1.52 m ²
The aspect ratio of the glass may be unlimited within these aperture dimensions		

PYRODUR® FIRE RESISTING GLASS

13 mm Pyrodur® 60-20 in timber framed screens for periods of 30 minutes integrity

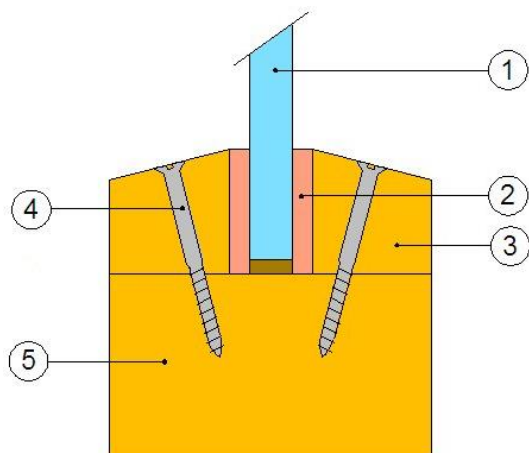

1. 13 mm thick Pyrodur® 60-20 glass.
2. Interdens, 20 mm by 2 mm.
3. Hardwood beads, 660 kg/m³ min. density, min. 20 mm high by 25 mm wide, square or up to 15° chamfer.
4. 38 mm pins or screws, 200 mm centres, fixed at 45°.
5. Hardwood, 660 kg/m³ min. density, min. 80 mm by 30 mm

This Certificate of Approval relates to the sizes of 13 mm Pyrodur® 60-20 shown in the table below, when used in conjunction with the above system:

	20 mm by 2 mm Interdens
Maximum Aperture Height	2456 mm (at 1213 mm wide)
Maximum Aperture Width	2500 mm (at 1192 mm high)
Maximum Aperture Area	2.98 m ²
The aspect ratio of the glass may be unlimited within these aperture dimensions	

PYRODUR® PLUS FIRE RESISTING GLASS

13 mm Pyrodur® 60-20 in timber based doorsets for periods of 60 minutes integrity

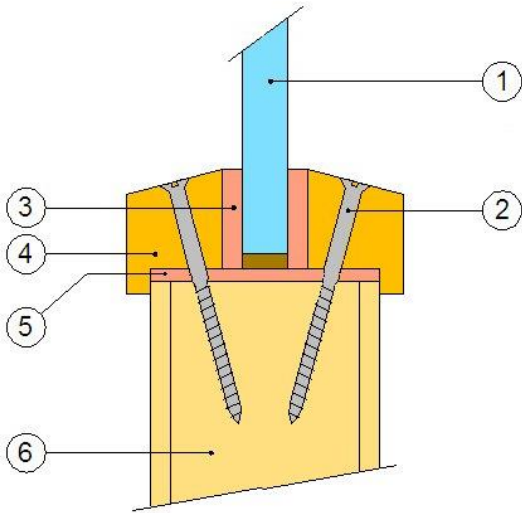

1. 13 mm thick Pyrodur® 60-20 glass.
2. 40 mm long (minimum) screw fixings at 150 mm centres angled at 30° to glass.
3. Sealmaster Fireglaze Mastic 20 mm by 4 mm
4. 25 mm high by 20 mm wide (including 5 mm by 5 mm bolection) square or chamfered (maximum of 15°) hardwood glazing beads of minimum 640 kg/m³ density
5. 54 mm wide by 2 mm thick GL60 aperture liner
6. Nominally 54 mm thick FD60 door leaf

The doorset shall have test evidence or be CERTIFIRE approved for the inclusion of apertures of the proposed dimensions.

This Certificate of Approval relates to the sizes of Pyrodur® 60-20 shown in the table below, when used in conjunction with the above system:

Maximum Aperture Height	Maximum Aperture Width	Maximum Aperture Area
2017 mm (at 526 mm wide)	647 mm (at 1640 mm high)	1.06 m ²
The aspect ratio of the glass may be unlimited within these aperture dimensions		

PYRODUR® FIRE RESISTING GLASS

13 mm Pyrodur® 60-20 in steel based doorsets for periods of 30 minutes integrity

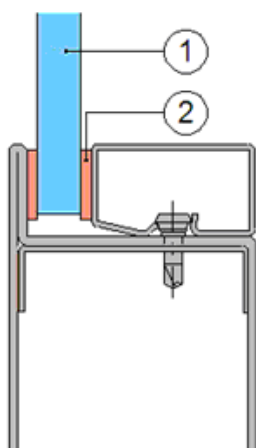

1. Pyrodur® 60-20 (13 mm thick)
2. Fibrefrax tape, 15 mm by 2 mm

The doorset shall have test evidence or be CERTIFIRE approved for the inclusion of apertures of the proposed dimensions. The specification of the glazing beads and their method of attachment shall also be as tested or CERTIFIRE approved.

This Certificate of Approval relates to the sizes of 13 mm Pyrodur® 60-20 shown in the table below, when used in conjunction with the above system:

Maximum Aperture Height	Maximum Aperture Width	Maximum Aperture Area
2415 mm	1069 mm	2.58 m ²
The aspect ratio of the glass may be unlimited within these aperture dimensions		

PYRODUR® FIRE RESISTING GLASS

13 mm Pyrodur® 60-20 in steel framed screens for periods of 30 minutes integrity

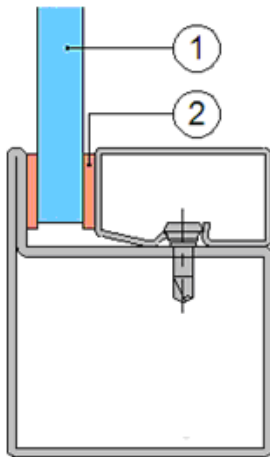

1. Pyrodur® 60-20 (13 mm thick)
2. Fibrefrax tape, 15 mm by 2 mm

The framing system shall have test evidence or be CERTIFIRE approved for the inclusion of apertures of the proposed dimensions.

This Certificate of Approval relates to the sizes of Pyrodur® 60-20 shown in the table below, when used in conjunction with the above systems:

Glazing Seal Reference	Maximum Aperture Height	Maximum Aperture Width	Maximum Aperture Area
15 mm by 2 mm Fibrefrax	3000 mm (at 1801 mm wide)	2561 mm (at 2000 mm high)	5.40 m ²
The aspect ratio of the glass may be unlimited within these aperture dimensions			

PYRODUR® FIRE RESISTING GLASS

13 mm Pyrodur® 60-20 in steel framed screens for periods of 60 minutes integrity

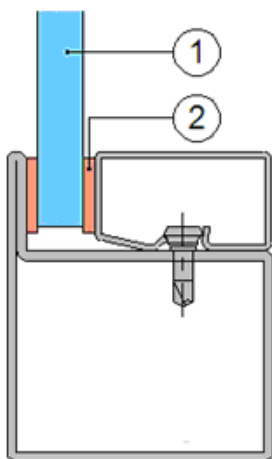

1. Pyrodur® 60-20 (13 mm thick)
2. Fibrefrax tape, 15 mm by 2 mm

This Certificate of Approval relates to the sizes of Pyrodur® 60-20 shown in the table below, when used in conjunction with the above systems:

Glazing Seal Reference	Maximum Aperture Height	Maximum Aperture Width	Maximum Aperture Area
15 mm by 2 mm Fibrefrax	2033 mm (at 1402 mm wide)	1688 mm (at 1688 mm high)	2.85 m ²
The aspect ratio of the glass may be unlimited within these aperture dimensions			

PYROSTOP® FIRE RESISTING GLASS

14 mm Pyrostop® 30-103 in timber doors for periods of 30 minutes integrity and 30 minutes insulation

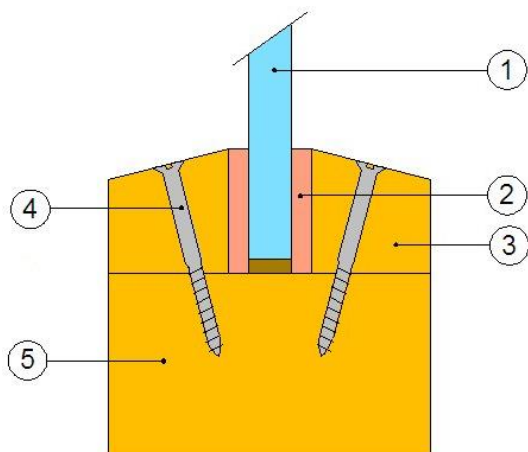

1. 14 mm thick Pyrostop® 30-103 glass.
2. Ceramic tape, 15x3mm (compressed to 2 mm). Ceramic fibre glazing tape may be replaced with any CERTIFIRE approved glazing gasket system.
3. Softwood or hardwood beads, 450 kg/m³ min. density, min. 18 mm high by 18 mm wide, square or up to 15° chamfer. Hardwood packers may be used.
4. 40 mm pins or screws, 50 mm in from corners, 150 mm centres, fixed at 45°.
5. 54 mm thick timber door leaf stile and rails or other 54 mm thick fire door leaf (450kg/m³ min. density)

This Certificate of Approval relates to the sizes of 14 mm Pyrostop® 30-103 shown in the table below, when used in conjunction with the above system:

Maximum Aperture Height	2243 mm (at 696 mm wide)
Maximum Aperture Width	856 mm (at 1824 mm high)
Maximum Aperture Area	1.56 m ²
The aspect ratio of the glass may be unlimited within these aperture dimensions	

PYROSTOP® FIRE RESISTING GLASS

14 mm Pyrostop® 30-103 in timber framed screens for periods of 30 minutes integrity and 30 minutes insulation

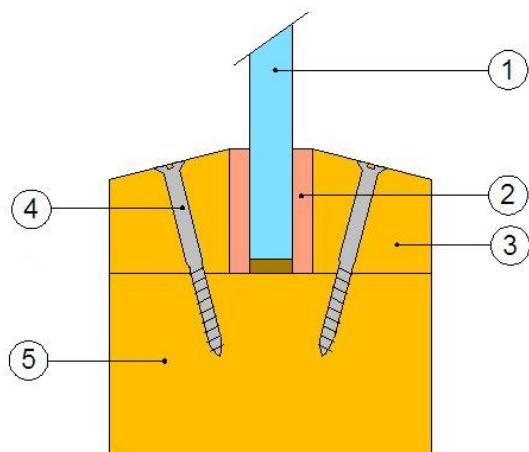

1. 14 mm thick Pyrostop® 30-103 glass.
2. Ceramic tape, 15x3mm (compressed to 2 mm), Ceramic fibre glazing tape may be replaced with any CERTIFIRE approved glazing gasket system.
3. Softwood beads, 450 kg/m³ min. density, min. 18 mm high by 18 mm wide, square or up to 15° chamfer. Hardwood packers may be used.
4. 40 mm pins or screws, 50 mm in from corners, 150 mm centres, fixed at 45°.
5. Softwood frame, 33 mm wide by 70 mm thick (450kg/m³ min. density)

This Certificate of Approval relates to the sizes of 14 mm Pyrostop® 30-103 shown in the table below, when used in conjunction with the above system:

	Portrait	Landscape
Maximum Aperture Height	2200 mm	961 mm (at 1889 mm wide)
Maximum Aperture Width	1000 mm	2323 mm (at 781 mm high)
Maximum Aperture Area	2.2 m ²	1.82 m ²
The aspect ratio of the glass may be unlimited within these aperture dimensions		

PYROSTOP® FIRE RESISTING GLASS

14 mm Pyrostop® 30-103 in steel framed screens for periods of 30 minutes integrity and 30 minutes insulation

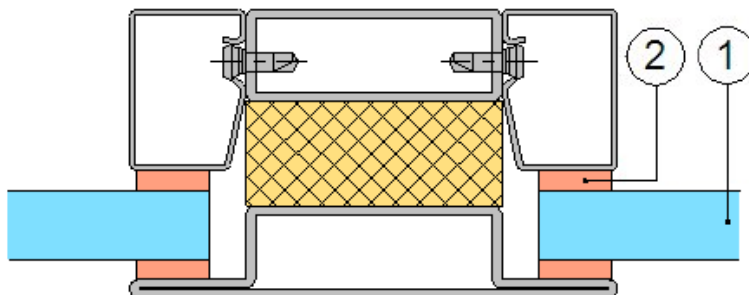

1. Pyrostop® 30-103 glass
2. 15 mm by 2 mm Fibrefrax glazing tape

This Certificate of Approval relates to the sizes of 14 mm Pyrostop® 30-103 shown in the table below, when used in conjunction with the above system:

	Portrait	Landscape
Maximum Aperture Height	2200 mm	961 mm (at 1889 mm wide)
Maximum Aperture Width	1000 mm	2323 mm (at 781 mm high)
Maximum Aperture Area	2.2 m ²	1.82 m ²
The aspect ratio of the glass may be unlimited within these aperture dimensions		

PYROSTOP® FIRE RESISTING GLASS

15 mm Pyrostop® 30-10 and 18 mm Pyrostop® 30-20 in timber framed screens for periods of 30 minutes integrity and insulation

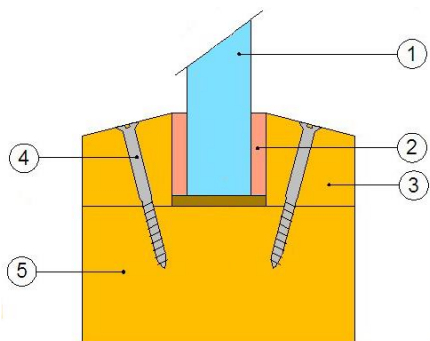

1. Pyrostop® glass (15/18 mm thick)
2. Fibrefrax, 15 mm by 2 mm
3. Hardwood beads, 640 kg/m³ minimum density, 20 mm high by 32 mm wide minimum dimensions, square or up to 15° chamfer.
4. 50 mm screws, 200 mm centres, fixed at 20°
5. Hardwood frame, 640 kg/m³ minimum density, 92 mm by 40 mm minimum section size.

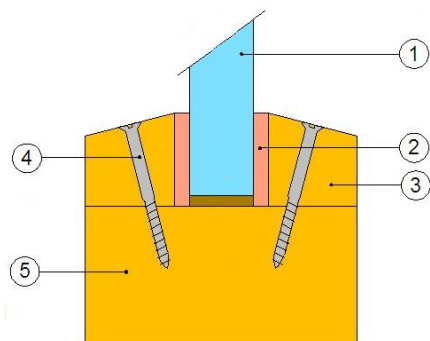

1. Pyrostop® glass (15/18 mm thick)
2. Interdens, 20 mm by 2 mm
3. Hardwood beads, 705 kg/m³ minimum density, 20 mm high by 30 mm wide minimum dimensions, square or up to 15° chamfer.
4. 50 mm screws, 200 mm centres, fixed at 20°
5. Hardwood frame, 705 kg/m³ minimum density, 82 mm by 40 mm minimum section size.

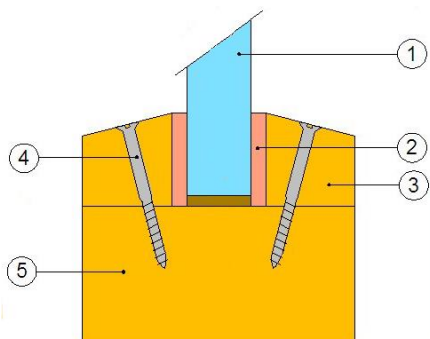

1. Pyrostop® glass (15/18 mm thick)
2. Fireglaze Compound, 15 mm by 2 mm
3. Hardwood beads, 600 kg/m³ minimum density, 15 mm high by 25 mm wide minimum dimensions, square or up to 15° chamfer.
4. 38mm screws or 32mm pins, 200mm centres, fixed at 20°
5. Hardwood frame, 600 kg/m³ minimum density, 80 mm by 25 mm minimum section size.

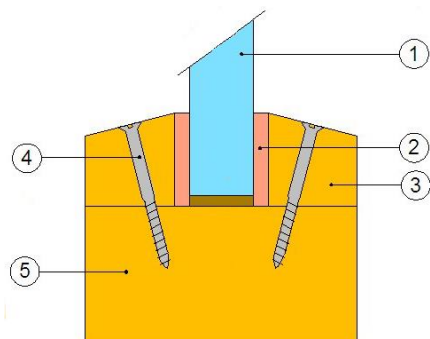

1. Pyrostop® glass (15/18 mm thick)
2. Fireglaze G30 Strip, 15 mm by 2 mm
3. Softwood or hardwood beads, 510 kg/m³ minimum density, 15 mm high by 25 mm wide minimum dimensions, square or up to 15° chamfer.
4. 50mm screws or pins, 150mm centres, fixed at 20°
5. Softwood or hardwood frame, 510 kg/m³ minimum density, 95 mm by 45 mm minimum section size.



PYROSTOP® FIRE RESISTING GLASS

15 mm Pyrostop® 30-10 and 18 mm Pyrostop® 30-20 in timber framed screens for periods of 30 minutes integrity and insulation (cont.)

This Certificate of Approval relates to the sizes of 15/18 mm Pyrostop® glass shown in the table below, when used in conjunction with the systems shown:

	15 mm by 2 mm Fibrefrax	20 mm by 2 mm Interdens	15 mm by 2 mm Fireglaze Compound	15 mm by 2 mm Fireglaze G30
Maximum Aperture Height	2500 mm (at 1752 mm wide)	2500 mm (at 1752 mm wide)	3000 mm (at 1750 mm wide)	3000 mm (at 1750 mm wide)
Maximum Aperture Width	2092 mm (at 2000 mm high*)	2092 mm (at 2000 mm high*)	2291 mm (at 2000 mm high*)	2291 mm (at 2000 mm high*)
Maximum Aperture Area	4.38 m ²	4.38 m ²	5.25 m ²	5.25 m ²
The aspect ratio of the glass may be unlimited within these aperture dimensions *Maximum pane height restricted to 2000 mm due to size of manufacturers stock plates				

PYROSTOP® FIRE RESISTING GLASS

15 mm Pyrostop® 30-10 in timber based doorsets for periods of 60 minutes integrity and 30 minutes insulation

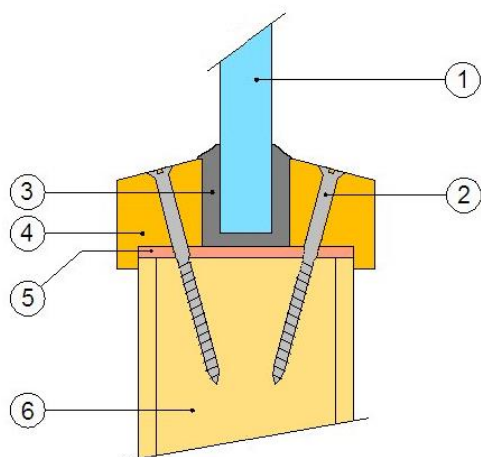

1. Pyrostop® glass (15 mm thick only)
2. 38 mm long (minimum) screw fixings at 150 mm centres angled at 20° to glass
3. System 36/15 glazing channel
4. Hardwood beads, 640 kg/m³ min. density, min. 24 mm high by 20 mm wide (including 4 mm high by 4 mm wide bolection), square or 15° chamfer
5. 54 mm by 2 mm thick Palusol liner or 12 mm thick softwood/hardwood of 440 kg/m³ min. density (only required if door leaf does not comprise softwood or hardwood core).
6. Nominally 54 mm thick FD60 door leaf

The doorset shall have test evidence or be CERTIFIRE approved for the inclusion of apertures of the proposed dimensions.

This Certificate of Approval relates to the sizes of Pyrostop® glass shown in the table below, when used in conjunction with the above system:

Maximum Aperture Height	Maximum Aperture Width	Maximum Aperture Area
1790 mm (at 615 mm wide)	630 mm (at 1762 mm high)	1.11 m ²
The aspect ratio of the glass may be unlimited within these aperture dimensions		

PYROSTOP® FIRE RESISTING GLASS

15 mm Pyrostop® 30-10 and 18 mm Pyrostop® 30-20 in timber framed screens for periods of 60 minutes integrity and 30 minutes insulation

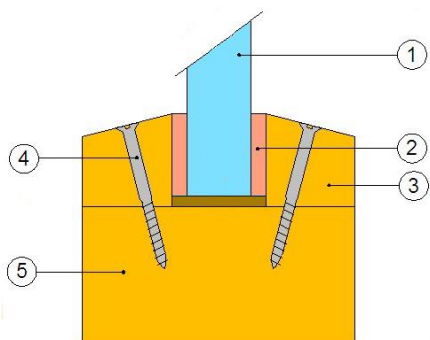

1. Pyrostop® glass (15/18 mm thick)
2. Fibrefrax, 15 mm by 2 mm
3. Hardwood beads, 705 kg/m³ minimum density, 20 mm high by 30 mm wide minimum dimensions, square or up to 15° chamfer.
4. 50 mm screws, 200 mm centres, fixed at 20°
5. Hardwood frame, 705 kg/m³ minimum density, 82 mm by 40 mm minimum section size.

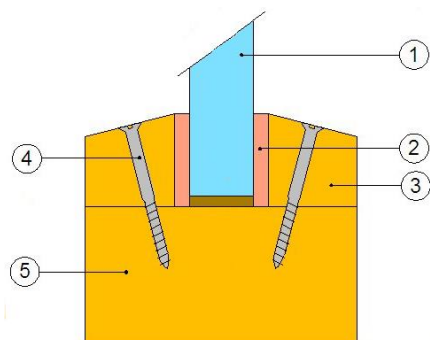

1. Pyrostop® glass (15/18 mm thick)
2. Interdens, 20 mm by 2 mm
3. Hardwood beads, 705 kg/m³ minimum density, 20 mm high by 30 mm wide minimum dimensions, square or up to 15° chamfer.
4. 50 mm screws, 200 mm centres, fixed at 20°
5. Hardwood frame, 705 kg/m³ minimum density, 82 mm by 40 mm minimum section size.

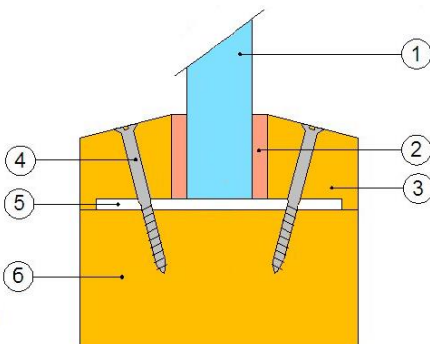

1. Pyrostop® glass (15/18 mm thick)
2. Fireglaze Compound, 20 mm by 4 mm
3. Hardwood beads, 600 kg/m³ minimum density, 20 mm high by 28 mm wide minimum dimensions, square or up to 25° chamfer.
4. 75 mm screws, 200mm centres, fixed at 20°
5. 54 mm by 2 mm GL60 liner
6. Hardwood frame, 600 kg/m³ minimum density, 90 mm by 45 mm minimum section size.

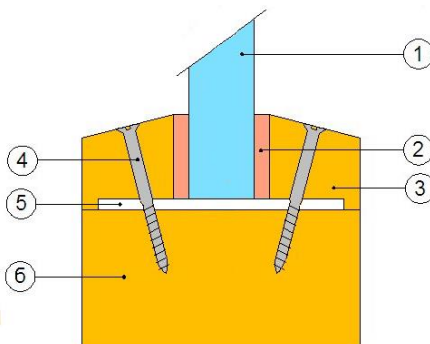

1. Pyrostop® glass (15/18 mm thick)
2. Fireglaze 2000, 20 mm by 4 mm
3. Hardwood beads, 600 kg/m³ minimum density, 20 mm high by 28 mm wide minimum dimensions, square or up to 25° chamfer.
4. 75mm screws, 180 mm centres, fixed at 20°
5. 63 mm by 2 mm Fireglaze liner
6. Hardwood frame, 600 kg/m³ minimum density, 90 mm by 45 mm minimum section size.

PYROSTOP® FIRE RESISTING GLASS

15 mm Pyrostop® 30-10 and 18 mm Pyrostop® 30-20 in timber framed screens for periods of 60 minutes integrity and 30 minutes insulation (cont.)

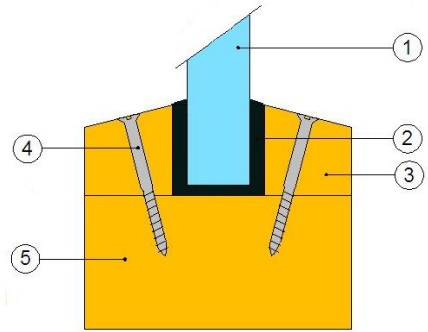

1. Pyrostop® glass (15 mm thick only)
2. System 36/15 glazing channel
3. Hardwood beads, 550 kg/m³ minimum density, 17 mm high by 21 mm wide minimum dimensions, square or up to 15° chamfer.
4. 45 mm screws, 200mm centres, fixed at 20°
5. Hardwood frame, 550 kg/m³ minimum density, 90 mm by 44 mm minimum section size.

This Certificate of Approval relates to the sizes of 15/18 mm Pyrostop® glass shown in the table below, when used in conjunction with the previously detailed systems:

	15 mm by 2 mm Fibrefrax	20 mm by 2 mm Interdens
Maximum Aperture Height	1118 mm (at 1118 mm wide)	2200 mm (at 1400 mm wide)
Maximum Aperture Width	1507 mm (at 829 mm high)	1755 mm (at 1755 mm high)
Maximum Aperture Area	1.25 m ²	3.08 m ²
The aspect ratio of the glass may be unlimited within these aperture dimensions		

	System 36/15 (only approved for use with 15 mm Pyrostop®)	20 mm by 4 mm Fireglaze Compound & GL60 liner	20 mm by 4 mm Fireglaze 2000 & Fireglaze liner
Maximum Aperture Height	2000 mm (at 950 mm wide)	3000 mm (at 1750 mm wide)	3000 mm (at 1750 mm wide)
Maximum Aperture Width	1340 mm (at 1418 mm high)	2300 mm (at 2000* mm high)	2300 mm (at 2000* mm high)
Maximum Aperture Area	1.90 m ²	5.25 m ²	5.25 m ²
The aspect ratio of the glass may be unlimited within these aperture dimensions			
*Maximum pane height restricted to 2000 mm due to size of manufacturers stock plates			

PYROSTOP® FIRE RESISTING GLASS

15 mm Pyrostop® 30-10 and 18 mm Pyrostop® 30-20 in insulated steel framed screens for periods of 30 minutes integrity and insulation

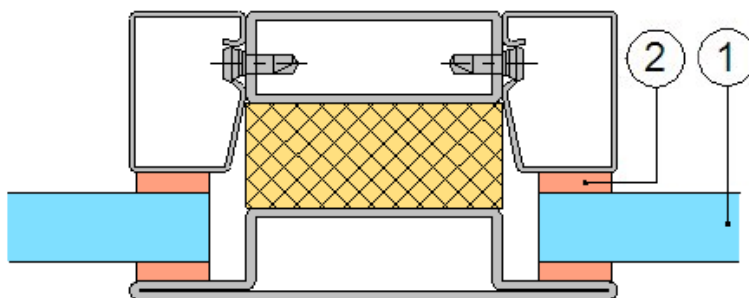

1. Pyrostop® glass (15/18 mm thick)
2. 15 mm by 2 mm Fibrefrax glazing tape

The framing system shall have test evidence or be CERTIFIRE approved for the inclusion of apertures of the proposed dimensions.

This Certificate of Approval relates to the sizes of 15/18 mm Pyrostop® glass shown in the table below, when used in conjunction with the above system:

Maximum Aperture Height	Maximum Aperture Width	Maximum Aperture Area
3000 mm (at 1502 mm wide)	2209 mm (at 2000 mm high)	4.51 m ²
The aspect ratio of the glass may be unlimited within these aperture dimensions		

PYROSTOP® FIRE RESISTING GLASS

15 mm Pyrostop® 30-10 and 18 mm Pyrostop® 30-20 in insulated steel framed screens for periods of 60 minutes integrity and 30 minutes insulation

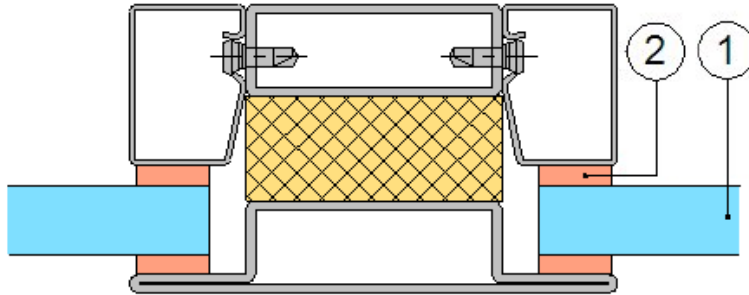

1. Pyrostop® glass (15/18 mm thick)
2. 15 mm by 2 mm Fibrefrax glazing tape

The framing system shall have test evidence or be CERTIFIRE approved for the inclusion of apertures of the proposed dimensions.

This Certificate of Approval relates to the sizes of 15/18 mm Pyrostop® glass shown in the table below, when used in conjunction with the above system:

Maximum Aperture Height	Maximum Aperture Width	Maximum Aperture Area
2860 mm (at 1200 mm wide)	1852 mm (at 1852 mm high)	3.43 m ²
The aspect ratio of the glass may be unlimited within these aperture dimensions		

PYROSTOP® FIRE RESISTING GLASS

Insulating Glass Units (IGU's) including 15 mm Pyrostop® 30-10 and 18 mm Pyrostop® 30-20 in timber or insulated steel framed screens for periods of 30 minutes integrity and insulation

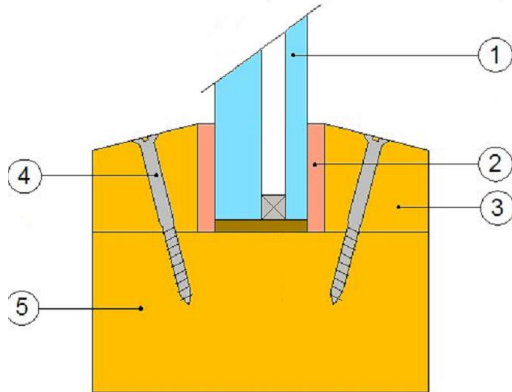

Options 1 & 2

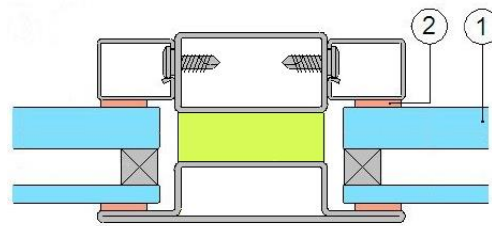

Option 3

Option 1

1. IGU (15/18 mm thick Pyrostop glass, 8 mm wide cavity, non-fire rated glass (toughened, float, laminated, coated, tinted))
2. Fibrefrax, 15 mm by 2 mm
3. Hardwood beads, 640 kg/m³ minimum density, 20 mm high by 32 mm wide minimum dimensions, square or up to 15° chamfer.
4. 50 mm screws, 200 mm centres, fixed at 20°
5. Hardwood frame, 640 kg/m³ minimum density, 92 mm by 40 mm minimum section size.

Option 2

1. IGU (15/18 mm thick Pyrostop glass, 8 mm wide cavity, non-fire rated glass (toughened, float, laminated, coated, tinted))
2. Interdens, 20 mm by 2 mm
3. Hardwood beads, 705 kg/m³ minimum density, 20 mm high by 30 mm wide minimum dimensions, square or up to 15° chamfer.
4. 50 mm screws, 200 mm centres, fixed at 20°
5. Hardwood frame, 640 kg/m³ minimum density, 82 mm by 40 mm minimum section size.

Option 3

1. 24 mm thick IGU (15/18 mm thick Pyrostop glass, 8 mm wide cavity, non-fire rated glass (toughened, float, laminated, coated, tinted))
2. Fibrefrax, 15 mm by 2 mm

The glass shall be glazed within a previously fire tested or CERTIFIRE approved insulated steel framing system



PYROSTOP® FIRE RESISTING GLASS

Insulating Glass Units (IGU's) including 15 mm Pyrostop® 30-10 and 18 mm Pyrostop® 30-20 in timber or insulated steel framed screens for periods of 30 minutes integrity and insulation (cont.)

This Certificate of Approval relates to the sizes of the IGU's shown in the table below, when used in conjunction with the previously mentioned systems:

Maximum Aperture Height	Maximum Aperture Width	Maximum Aperture Area
2820 mm (at 1216 mm wide)	1850 mm (at 1850 mm high)	3.43 m ²
The aspect ratio of the glass may be unlimited within these aperture dimensions		

PYROSTOP® FIRE RESISTING GLASS

Insulating Glass Units (IGU's) including 15 mm Pyrostop® 30-10 and 18 mm Pyrostop® 30-20 in timber or insulated steel framed screens for periods of 60 minutes integrity and 30 minutes insulation

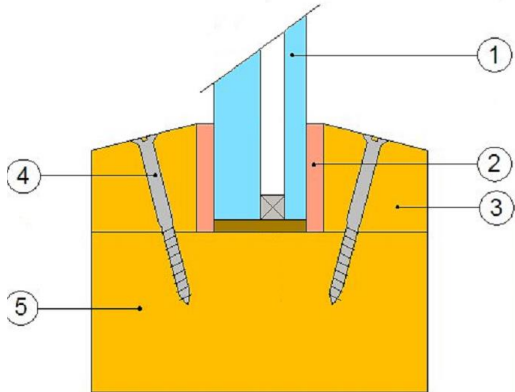

1. IGU (15/18 mm thick Pyrostop® glass, 8 mm wide cavity, non-fire rated glass (toughened, float, laminated, coated, tinted))
2. Interdens, 20 mm by 2 mm or Fibrefrax, 15 mm by 2 mm
3. Hardwood beads, 705 kg/m³ minimum density, 20 mm high by 30 mm wide minimum dimensions, square or up to 15° chamfer.
4. 50 mm screws, 200 mm centres, fixed at 20°
5. Hardwood frame, 640 kg/m³ minimum density, 82 mm by 40 mm minimum section size.

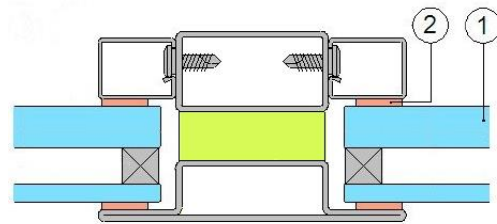

1. IGU (15/18 mm thick Pyrostop® glass, 8 mm wide cavity, non-fire rated glass (toughened, float, laminated, coated, tinted))
2. Fibrefrax, 15 mm by 2 mm

The glass shall be glazed within a previously fire tested or CERTIFIRE approved insulated steel framing system

This Certificate of Approval relates to the sizes of the IGU's shown in the table below, when used in conjunction with the above systems:

Maximum Aperture Height	Maximum Aperture Width	Maximum Aperture Area
2820 mm (at 1216 mm wide)	1850 mm (at 1850 mm high)	3.43 m ²
The aspect ratio of the glass may be unlimited within these aperture dimensions		

PYROSTOP® FIRE RESISTING GLASS

23 mm Pyrostop® 60-101 in timber framed screens for periods of 60 minutes integrity and insulation

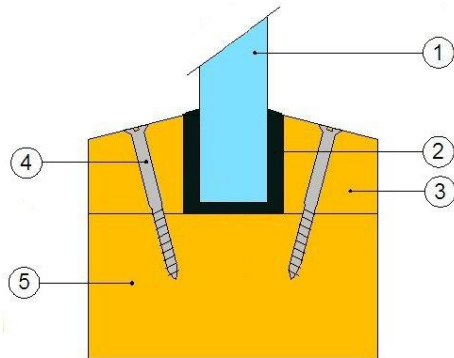

1. 23 mm thick Pyrostop® 60-101
2. Lorient System 36/21
3. Hardwood beads, 550 kg/m³ minimum density, 20 mm high by 21 mm wide minimum
4. 45 mm screws, 200 mm centres, fixed at 20°
5. Hardwood frame, 550 kg/m³ minimum density, 90 mm by 44 mm minimum section size.

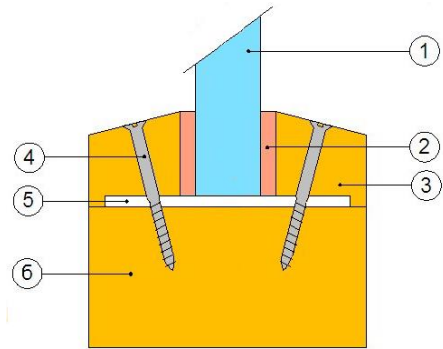

1. 23 mm thick Pyrostop® 60-101
2. Fireglaze Compound, 20 mm by 4 mm
3. Hardwood beads, 600 kg/m³ minimum density, 20 mm high by 28 mm wide minimum dimensions, square or up to 25° chamfer.
4. 75 mm screws, 200mm centres, fixed at 20°
5. 54 mm by 2 mm GL60 liner
6. Hardwood frame, 600 kg/m³ minimum density, 90 mm by 45 mm minimum section size.

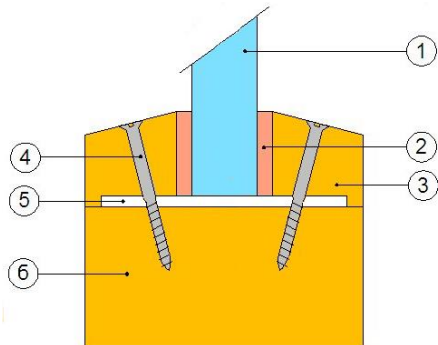

1. 23 mm thick Pyrostop® 60-101
2. Fireglaze 2000, 20 mm by 4 mm
3. Softwood beads, 490 kg/m³ minimum density, 20 mm high by 28 mm wide minimum dimensions, square or up to 15° chamfer.
4. 75mm screws, 180 mm centres, fixed at 20°
5. 63 mm by 2 mm Fireglaze liner
6. Softwood frame, 490 kg/m³ minimum density, 90 mm by 44 mm minimum section size.



PYROSTOP® FIRE RESISTING GLASS

23 mm Pyrostop® 60-101 in timber framed screens for periods of 60 minutes integrity and insulation (continued)

This Certificate of Approval relates to the sizes of 23 mm Pyrostop® 60-101 shown in the table below, when used in conjunction with the previously mentioned systems:

	System 36/21	20 mm by 4 mm Fireglaze Compound and GL60 Liner	Fireglaze 2000
Maximum Aperture Height	2000 mm (at 900 mm wide)	3000 mm (at 1750 mm wide)	3000 mm (at 1750 mm wide)
Maximum Aperture Width	1270 mm (at 1417 mm high)	2300 mm (at 2000 mm high*)	2300 mm (at 2000 mm high*)
Maximum Aperture Area	1.80 m ²	5.25 m ²	5.25 m ²
The aspect ratio of the glass may be unlimited within these aperture dimensions			
*Maximum pane height is restricted to 2000 mm due to size of manufacturers stock plates			

PYROSTOP® FIRE RESISTING GLASS

23 mm Pyrostop® 60-101 in insulated steel framed screens for periods of 60 minutes integrity and insulation

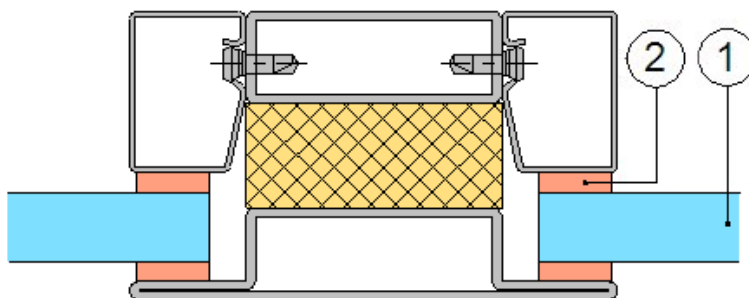

1. Pyrostop® 60-101 (23 mm thick)
2. 15 mm by 2 mm Fibrefrax glazing tape

The framing system shall have test evidence or be CERTIFIRE approved for the inclusion of apertures of the proposed dimensions.

This Certificate of Approval relates to the sizes of 23 mm Pyrostop® 60-101 shown in the table below, when used in conjunction with the above system:

Maximum Aperture Height	Maximum Aperture Width	Maximum Aperture Area
2713 mm (at 1570 mm wide)	2064 mm (at 2000 mm high*)	4.26 m ²
The aspect ratio of the glass may be unlimited within these aperture dimensions *Maximum pane height is restricted to 2000 mm due to size of manufacturers stock plates		

PYROSTOP® FIRE RESISTING GLASS

23 mm Pyrostop® 60-101 in insulated steel based doorsets for periods of 60 minutes integrity and insulation

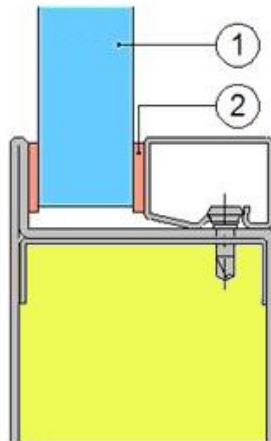

1. Pyrostop® 60-101 (23 mm thick)
2. 12 mm by 6 mm Fibrefrax glazing tape

The doorset shall have test evidence or be CERTIFIRE approved (as a fully insulated assembly) for the inclusion of apertures of the proposed dimensions.

This Certificate of Approval relates to the sizes of 23 mm Pyrostop® 60-101 shown in the table below, when used in conjunction with the above system:

Maximum Aperture Height	Maximum Aperture Width	Maximum Aperture Area
2280 mm (at 785 mm wide)	1338 mm (at 1338 mm high)	1.79 m ²
The aspect ratio of the glass may be unlimited within these aperture dimensions		

PYROSTOP® FIRE RESISTING GLASS

Insulating Glass Units (IGU's) including 23 mm Pyrostop® 60-101 in insulated steel framed screens for periods of 60 minutes integrity and insulation

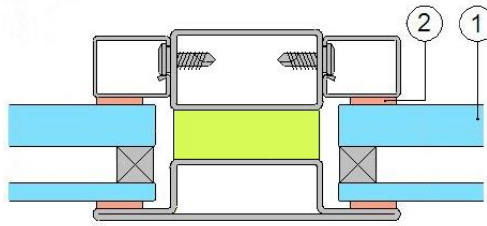

1. IGU comprising 23 mm thick Pyrostop® 60-101, an 8 mm deep air cavity and 6 mm thick non-fire rated glass (toughened, float, laminated, coated, tinted)
2. 15 mm by 2 mm Fibrefrax glazing tape

The fire performance of the insulated steel framing system shall be supported by appropriate fire test evidence.

This Certificate of Approval relates to the sizes of the IGU's shown in the table below, when used in conjunction with the above system:

Maximum Aperture Height	2500 mm (at 1652 mm wide)
Maximum Aperture Width	2031 mm (at 2000 mm high*)
Maximum Aperture Area	4.13 m ²
The aspect ratio of the glass may be unlimited within these aperture dimensions *Maximum pane height is restricted to 2000 mm due to size of manufacturers stock plates	

PYROSTOP® FIRE RESISTING GLASS

Insulating Glass Units (IGU's) including 23 mm Pyrostop® 60-101 in timber framed screens for periods of 60 minutes integrity and insulation

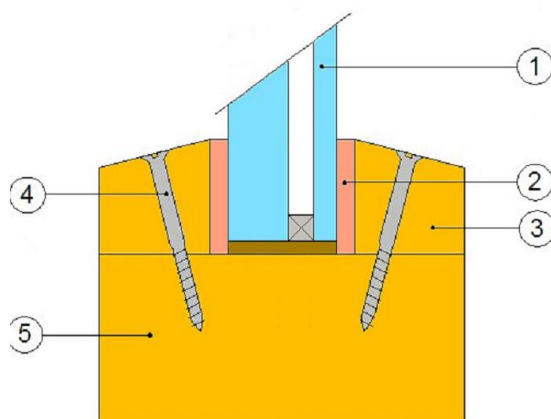

1. IGU comprising 23 mm thick Pyrostop® 60-101, an 8 mm deep air cavity and 6 mm thick non-fire rated glass (toughened, float, laminated, coated, tinted)
2. 20 mm by 2 mm Interdens glazing tape
3. Hardwood beads, 640 kg/m³ minimum density, 20 mm high by 31 mm wide minimum with 15° chamfer
4. Minimum 60 mm screws, at minimum 150 mm centres, fixed at 30°
5. Hardwood frame, 640 kg/m³ minimum density, 120 mm by 40 mm minimum section size.

The fire performance of the timber framing system shall be supported by appropriate fire test evidence.

This Certificate of Approval relates to the sizes of the IGU's shown in the table below, when used in conjunction with the above system:

Aspect Ratio	Option 1	Option 2
Maximum Aperture Height	3000 mm* (at 1260 mm wide)	2344 mm (at 1620 mm wide)
Maximum Aperture Width	1575 mm (at 2510 mm high)	2025 mm (at 1875 mm high)
Maximum Aperture Area	3.95 m ²	3.8 m ²
The aspect ratio of the glass may be unlimited within these aperture dimensions		
*Maximum pane height is restricted to 3000 mm due to size of manufacturers stock plates		

PYROSTOP® FIRE RESISTING GLASS

23 mm Pyrostop® 60-101 and 27 mm Pyrostop® 60-201 in timber framed screens for periods of 60 minutes integrity and insulation

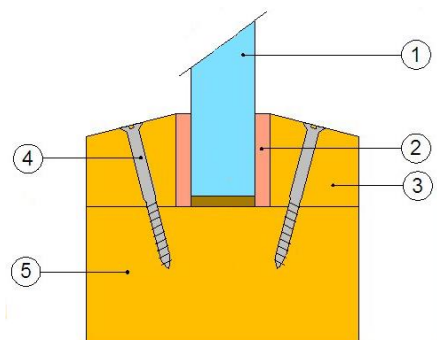

1. Pyrostop® glass (23/27 mm thick)
2. Interdens, 20 mm by 2 mm
3. Hardwood beads, 640 kg/m³ minimum density, 20 mm high by 30 mm wide minimum dimensions, square or up to 15° chamfer.
4. 60 mm screws, 200 mm centres, fixed at 30°
5. Hardwood frame, 640 kg/m³ minimum density, 95 mm by 45 mm minimum section size.

This Certificate of Approval relates to the sizes of 23/27 mm Pyrostop® glass shown in the table below, when used in conjunction with the above system:

Maximum Aperture Height	Maximum Aperture Width	Maximum Aperture Area
3000 mm* (at 1563 mm wide)	2343 mm (at 2000 mm high*)	4.69 m ²
The aspect ratio of the glass may be unlimited within these aperture dimensions *Restricted to this dimension by manufacturing limits and/or plate stock sizes		

PYROSTOP® FIRE RESISTING GLASS

23 mm Pyrostop® 60-101 and 27 mm Pyrostop® 60-201 in insulated steel framed screens for periods of 60 minutes integrity and insulation

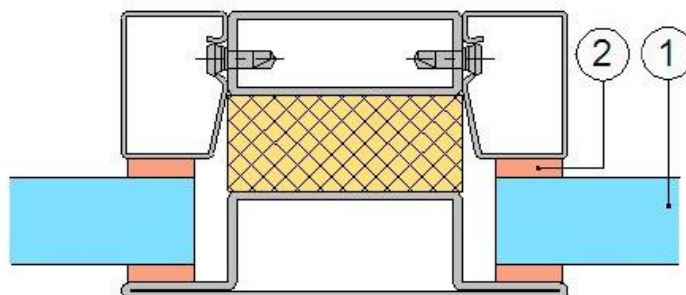

1. Pyrostop® glass (23/27 mm thick)
2. 15 mm by 2 mm Fibrefrax glazing tape

The framing system shall have test evidence or be CERTIFIRE approved for the inclusion of apertures of the proposed dimensions.

This Certificate of Approval relates to the sizes of 23/27 mm Pyrostop® glass shown in the table below, when used in conjunction with the above system:

Maximum Aperture Height	Maximum Aperture Width	Maximum Aperture Area
3000 mm (at 1494 mm wide)	2326 mm (at 1926 mm high)	4.48 m ²
The aspect ratio of the glass may be unlimited within these aperture dimensions		

PYROSTOP® FIRE RESISTING GLASS

23 mm Pyrostop® 60-101 and 27 mm Pyrostop® 60-201 in insulated steel based doorsets for periods of 60 minutes integrity and insulation

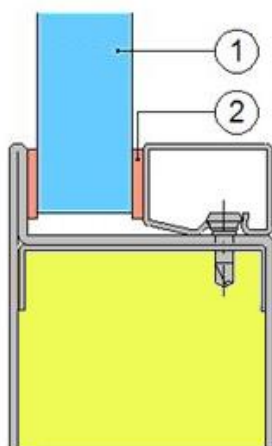

1. Pyrostop® glass (23/27 mm thick)
2. 12 mm by 6 mm Fibrefrax glazing tape

The doorset shall have test evidence or be CERTIFIRE approved for the inclusion of apertures of the proposed dimensions.

This Certificate of Approval relates to the sizes of 23/27 mm Pyrostop® glass shown in the table below, when used in conjunction with the above system:

Maximum Aperture Height	Maximum Aperture Width	Maximum Aperture Area
2280 mm (at 785 mm wide)	1338 mm (at 1338 mm high)	1.79 m ²
The aspect ratio of the glass may be unlimited within these aperture dimensions		

PYROSTOP® FIRE RESISTING GLASS

Insulating Glass Units (IGU's) including 23 mm Pyrostop® 60-101 and 27 mm Pyrostop® 60-201 in timber or insulated steel framed screens for periods of 60 minutes integrity and insulation

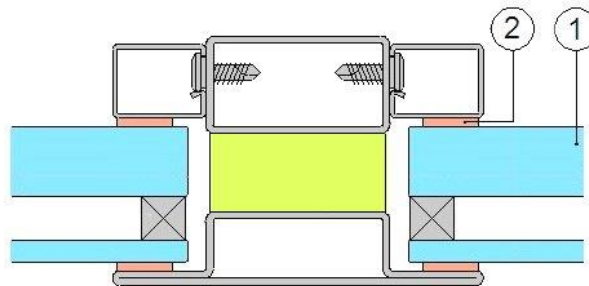

1. IGU comprising 23/27 mm thick Pyrostop® glass, an 8 mm deep air cavity and 6 mm thick non-fire rated glass (toughened, float, laminated, coated, tinted)
2. 15 mm by 2 mm Fibrefrax glazing tape

This Certificate of Approval relates to the sizes of the IGU's shown in the table below, when used in conjunction with the above systems:

Maximum Aperture Height	2500 mm (at 1652 mm wide)
Maximum Aperture Width	2031 mm (at 2031 mm high)
Maximum Aperture Area	4.13 m ²
The aspect ratio of the glass may be unlimited within these aperture dimensions	

PYROSTOP® FIRE RESISTING GLASS

23 & 27 mm Pyrostop® Line 60-603 (Butt Jointed) in timber framed screens for periods of 30 & 60 minutes integrity and insulation

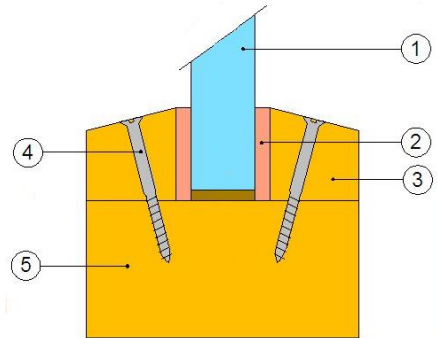

1. Pyrostop® Line glass (23 & 27 mm thick). For 27 mm thick option, PVB interlayer to fire side only
2. Kerafix 2000/mineral fibre, 15 mm x 5 mm capped with Ceresit 3B silicone by Henkel
3. Softwood beads, 450 kg/m³ minimum density, 20 mm high by 20 mm wide minimum dimensions, square or up to 15° chamfer.
4. 45 mm screws, 4 mm diameter, 250 mm centres, fixed at 30°
5. Softwood frame, 450 kg/m³ minimum density, 75 mm by 33 mm minimum section size.



Butt jointed comprises Kerafix 2000/mineral fibre, 15 mm x 5 mm capped with Ceresit 3B silicone by Henkel

This Certificate of Approval relates to the sizes of 23 & 27 mm Pyrostop® Line 60-603 glass shown in the table below, when used in conjunction with the above system:

Maximum Aperture Height	Maximum Aperture Width	Maximum Aperture Area
3000 mm* (at 1297 mm wide)	1427 mm (at 2884 mm high*)	4.11 m ²
The aspect ratio of the glass may be unlimited within these aperture dimensions		

PYROSTOP® FIRE RESISTING GLASS

23 & 27 mm Pyrostop® Line 60-603 (Butt Jointed) in steel framed screens for periods of 30 & 60 minutes integrity and insulation

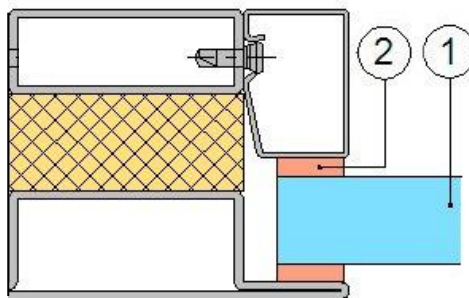

1. Pyrostop® glass (23/27 mm thick)
2. 15 mm by 2 mm Fibrefrax glazing tape



Butt jointed comprises Kerafix 2000/mineral fibre, 15 mm x 5 mm capped with Ceresit 3B silicone by Henkel

This Certificate of Approval relates to the sizes of 23 & 27 mm Pyrostop® Line 60-603 glass shown in the table below, when used in conjunction with the above system:

Maximum Aperture Height	Maximum Aperture Width	Maximum Aperture Area
3000 mm (at 1297 mm wide)	1493 mm (at 3000 mm high*)	4.48 m ²
The aspect ratio of the glass may be unlimited within these aperture dimensions		

PYROSTOP® FIRE RESISTING GLASS

Insulating Glass Units (IGU's) including 15 mm Pyrostop® 30-10, 18 mm Pyrostop® 30-10, 23 mm Pyrostop® 60-101, 27 mm Pyrostop® 60-201, in insulated steel framed screens for periods of 90 minutes integrity and insulation

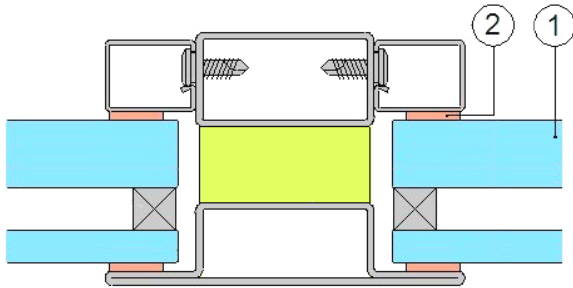

1. A combination of 15/18 mm thick Pyrostop®, an 8 mm deep air cavity and 23 mm or 27 mm thick Pyrostop® (e.g. 27 + 15 mm, 23 + 15 mm or 18 + 23 mm). The increased thickness may be achieved via the additional lamination of a 'non-fire rated' type glass including acid etched, patterned, toughened, float, laminated, coated, tinted). For external applications, 27 or 18 mm thickness shall be used as outer pane
2. 15 mm by 2 mm Fibrefrax glazing tape

The glass shall be glazed within a previously fire tested or CERTIFIRE approved insulated steel framing system utilising Fibrefrax glazing tape. Alternative gaskets are acceptable on the basis that they possess relevant test data when used in conjunction with the proposed frame for the required period of 90 minutes integrity and insulation

This Certificate of Approval relates to the sizes of the IGU's shown in the table below, when used in conjunction with the above systems:

Maximum Aperture Height	Maximum Aperture Width	Maximum Aperture Area
2000 mm (at 1400 mm wide)	1400 mm (at 2000 mm high)	2.80 m ²
The aspect ratio of the glass may be unlimited within these aperture dimensions		

PYROSTOP® FIRE RESISTING GLASS

Insulating Glass Units (IGU's) including 23 mm Pyrostop® 60-101 in insulated steel framed screens for periods of 120 minutes integrity and insulation

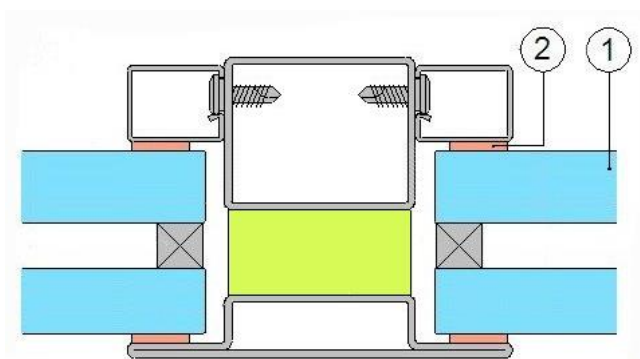

1. 23 mm thick Pyrostop® 60-101, a 6 mm deep air cavity and a 23 mm thick Pyrostop® 60-101 pane. For external applications use 27 mm thick Pyrostop® 60-201, see overleaf.
2. 15 mm by 2 mm Fibrefrax glazing tape

The glass shall be glazed within a previously fire tested or CERTIFIRE approved insulated steel framing system utilising Fibrefrax glazing tape. Alternative gaskets are acceptable on the basis that they possess relevant test data when used in conjunction with the proposed frame for the required period of 120 minutes integrity and insulation

This Certificate of Approval relates to the sizes of the IGU's shown in the table below, when used in conjunction with the above systems:

Maximum Aperture Height	Maximum Aperture Width	Maximum Aperture Area
2000 mm (at 1400 mm wide)	1400 mm (at 2000 mm high)	2.80 m ²
The aspect ratio of the glass may be unlimited within these aperture dimensions		

PYROSTOP® FIRE RESISTING GLASS

Insulating Glass Units (IGU's) including 23 mm Pyrostop® 60-101 and 27 mm Pyrostop® 60-201 in insulated steel framed screens for periods of 120 minutes integrity and insulation

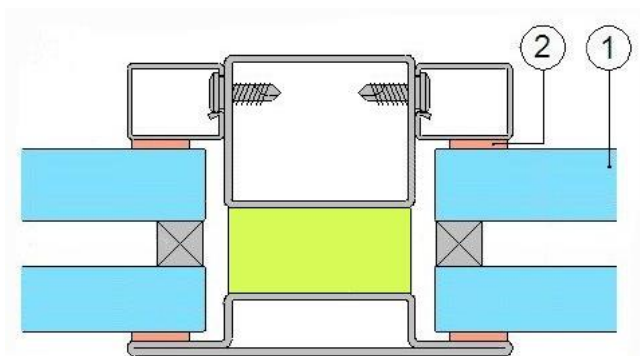

1. A pane of 23 mm Pyrostop® 60-101 or 27 mm Pyrostop® 60-201, a 6 mm deep air cavity and 23 mm Pyrostop® 60-101 or 27 mm Pyrostop® 60-201, 27 mm for use externally.
2. 15 mm by 2 mm Fibrefrax glazing tape

The glass shall be glazed within a previously fire tested or CERTIFIRE approved insulated steel framing system utilising Fibrefrax glazing tape. Alternative gaskets are acceptable on the basis that they possess relevant test data when used in conjunction with the proposed frame for the required period of 120 minutes integrity and insulation

This Certificate of Approval relates to the sizes of the IGU's shown in the table below, when used in conjunction with the above systems:

Maximum Aperture Height	Maximum Aperture Width	Maximum Aperture Area
2520 mm (at 1415 mm wide)	1889 mm (at 1889 mm high)	3.57 m ²
The aspect ratio of the glass may be unlimited within these aperture dimensions		



PYROSTOP®/PYRODUR® FIRE RESISTING GLASS

Pyrostop®/Pyrodur® Glass within SAPA Building Systems proprietary aluminium glazed screens.

The glass shall be glazed within a SAPA Building Systems aluminium framed glazed screens utilising one of the following basic specifications:

- 10 mm thick Pyrodur® 30-201 & 30-203, 15 mm thick Pyrostop® 30-10 or 18 mm thick Pyrostop® 30-20

The framing system shall have test evidence or be CERTIFIRE approved for the inclusion of apertures of the proposed dimensions.

This Certificate of Approval relates to the sizes of 10 mm thick Pyrodur® 30-201 & 30-203 or 15/18 mm thick Pyrostop® (30-10 or 30-20) shown in the table below, when used in conjunction with the above system:

Glass Specification	Fire Resistance Performance (mins)		Maximum Aperture Height	Maximum Aperture Width	Maximum Aperture Area
	Integrity	Insulation			
10 mm thick Pyrodur®	30	-	2000 mm (at 1200 mm wide)	1200 mm (at 2000 mm high)	2.40 m ²
15/18 mm thick Pyrostop®	60	30	2000 mm (at 1200 mm wide)	1200 mm (at 2000 mm high)	2.40 m ²

The aspect ratio of the glass may be unlimited within these aperture dimensions



PYROSTOP® FIRE RESISTING GLASS

Pyrostop® Glass within SAPA Building Systems proprietary aluminium glazed doorsets.

The glass shall be glazed within a SAPA Building Systems aluminium framed glazed doorsets utilising the following basic specification:

- 15 mm thick Pyrostop® 30-10 or 18 mm thick Pyrostop® 30-20

The doorset shall have test evidence or be CERTIFIRE approved for the inclusion of apertures of the proposed dimensions.

This Certificate of Approval relates to the sizes of Pyrostop® glass shown in the table below, when used in conjunction with the above system:

Glass Specification	Fire Resistance Performance (mins)		Maximum Aperture Height	Maximum Aperture Width	Maximum Aperture Area
	Integrity	Insulation			
15/18 mm thick Pyrostop®	60	30	1832 mm (at 648 mm wide)	648 mm (at 1832 mm high)	1.19 m ²
The aspect ratio of the glass may be unlimited within these aperture dimensions					